

ROTEX®
Torsionally flexible coupling with T-PUR®

Made for Motion



Table of contents



ROTEX®	
Torsionally flexible coupling	17
Description of coupling	19
Coupling selection	20
Displacements	22
Selection of standard IEC motors	23
Properties of our standard spiders	24
Technical data of our standard spiders	25
Technical data and properties of the special spiders	26
Installation spider	26
Hub designs	27
Cylindrical bores and spline bores	28
Inch bores and taper bores	29
Shaft coupling - casted materials	30
Shaft coupling - material steel	31
Shaft coupling with taper clamping bush	32
Clamping ring hubs	33
Clamping hubs	34
Flange programme types AFN and BFN	35
Drop-out center design coupling type A-H	36
Flange programme types CF, CFN, DF and DFN	37
Double cardanic type ZS-DKM-H	38
Double cardanic type DKM	39
Intermediate shaft programme type ZR	40
Type BTAN with brake drum/type SBAN with disk brake	41
Type AFN-SB special with disk brake	42
Type SD (shiftable at standstill)	43
Type FNN and FNN with fan	44
Further types with clamping sets	45
Further types with torque limiter	46
Weights and mass moment of inertia	47

Description of coupling

ROTEX® - couplings are characterized by small dimensions, low weight and low mass moments of inertia yet transmit high torques. Running quality and service life of the coupling are improved by accurate all-over machining.

Their application is ideal for transmitting torque while damping torsional vibrations and absorbing shocks produced by the uneven operation of certain prime movers.

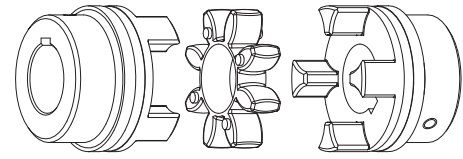

General description

ROTEX® - couplings are torsionally flexible and designed for positive torque transmission. They are fail-safe. Operational vibrations and shocks are efficiently dampened and reduced. The two congruent coupling halves with concave claws on the inside are periphally offset in relation to one another by half a pitch. In addition, they are designed in such a way as to enable an involute spider to be located between them.

The teeth of the spider are crowned to avoid edge pressure if the shafts are misaligned. ROTEX® couplings are capable of compensating for axial, radial and angular displacements of the shafts to be connected.

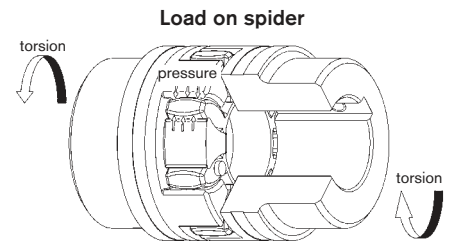

Deformation with load

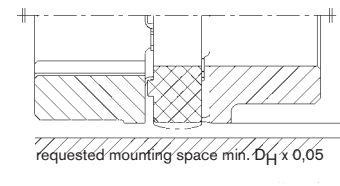

Performance

In contrast to other flexible couplings, the intermediate members of which are subject to bending stress and are therefore prone to earlier wear, the flexible teeth of ROTEX® couplings are subject to pressure only. This gives the additional advantage of the individual teeth being able to accept considerably higher loads. The elastomer parts show deformation with load and excessive speeds. Sufficient space for expansion should be ensured (see drawing – deformation with load).

The maximum torsion angle with ROTEX® couplings of any size amounts to 5°. They can be fitted both horizontally and vertically.

Spiders – our innovation T-PUR®

KTR has developed a new standard material for its spiders. The improved polyurethane material **T-PUR®** is resistant to significantly higher temperatures and has a considerably longer service life than the previous polyurethane material. From the visual point of view we have characterized the material **T-PUR®** by the colours orange (92 Shore-A), purple (98 Shore-A) and pale green (64 Shore-D). The previous spiders made from polyurethane in yellow, red and natural white with green ends will still be available. Up to size ROTEX® 90 inclusive single spiders are used. For ROTEX® couplings from size 100 to 180 the spider consists of DZ tooth segments as a standard. The single spider will still be available in these sizes as an option.

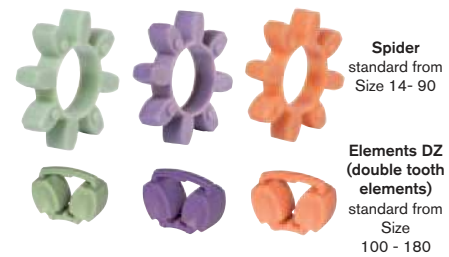

Explosion-proof use

ROTEX® couplings are suitable for power transmission in drives in hazardous areas. The couplings are certified and confirmed according to EC standard 94/9/EC (ATEX 95) as units of category 2G/2D and thus suitable for the use in hazardous areas of zone 1, 2, 21 and 22. Please read through our information included in the respective Type Examination Certificate and the operating and mounting instructions at www.ktr.com.



Comparison of loads

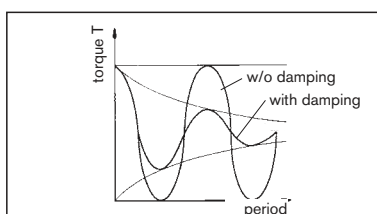

Twisting angle

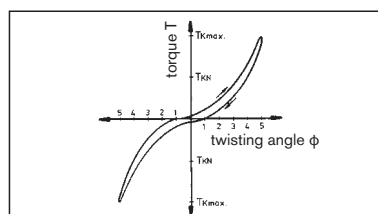

Damping

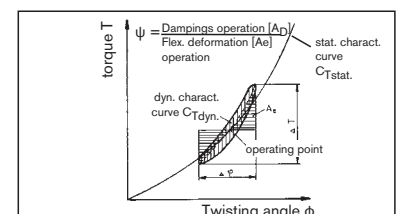

Coupling selection

The ROTEX® coupling is selected in accordance with DIN 740 part 2. The coupling has to be dimensioned in a way that the permissible coupling load is not exceeded in any operating condition. For this purpose the actual loads have to be compared to the permissible parameters of the coupling. The torques T_{KN}/T_{Kmax} mentioned refer to the spider. The shaft-hub-connection has to be investigated by the customer.

1 Drives without periodical torsional vibrations

e. g. centrifugal pumps, fans, screw compressors, etc.

The coupling is selected taking into account the rated torques

T_{KN} and maximum torque T_{Kmax}

1.1 Load produced by rated torque

Taking into consideration the ambient temperature, the permissible rated torque T_{KN} of the coupling has to correspond at least to the rated torque T_N of the machine.

$$T_N \text{ [Nm]} = 9550 \cdot \frac{P \text{ [kW]}}{n \text{ [rpm]}}$$

$$T_{KN} \geq T_N \cdot S_t$$

1.2 Load produced by torque shocks

The permissible maximum torque of the coupling has to correspond at least to the total of peak torque T_S and the rated torque T_N of the machine, taking into account the shock frequency Z and the ambient temperature.

This applies in case if the rated torque T_N of the machine is at the same time subject to shocks.

Knowing the mass distribution, shock direction and shock mode, the peak torque T_S can be calculated.

For drives with A. C.-motors with high masses on the load side we would recommend to calculate the peak driving torque with the help of our simulation programme.

$$T_{Kmax} \geq T_S \cdot S_z \cdot S_t + T_N \cdot S_t$$

$$\text{Drive-sided shock } T_S = T_{AS} \cdot M_A \cdot S_A$$

$$\text{Load-sided shock } T_S = T_{LS} \cdot M_L \cdot S_L$$

$$M_A = \frac{J_L}{J_A + J_L} \quad M_L = \frac{J_A}{J_A + J_L}$$

2. Drives with periodical torsional vibrations.

For drives subject to high torsional vibrations, e. g. diesel engines, piston compressors, piston pumps, generators, etc., it is necessary to perform a torsional vibration calculation to ensure a safe operation. If requested, we perform the torsional vibration calculation and the coupling selection in our company. For necessary details please see KTR standard 20004.

2.1 Load produced by rated torque

Taking into account the ambient temperature, the permissible rated torque T_{KN} of the coupling has to correspond at least to the rated torque T_N of the machine.

$$T_{KN} \geq T_N \cdot S_t$$

2.2 Passing through the resonance range

Taking into account the temperature, the peak torque T_S arising when the resonance range is run through must not exceed the maximum torque T_{Kmax} of the coupling.

$$T_{Kmax} \geq T_S \cdot S_t$$

2.3 Load produced by vibratory torque shocks

Taking into account the ambient temperature, the permissible vibratory torque T_{KW} of the coupling must not be exceeded by the highest periodical vibratory torque T_W with operating speed.

$$T_{KW} \geq T_W \cdot S_t$$

For higher operating frequencies $f > 10$, the heat produced by damping in the elastomer part is considered as damping power P_W .

The permissible damping power P_{KW} of the coupling depends on the ambient temperature and must not be exceeded by the damping power produced.

$$P_{KW} \geq P_W$$

Description	Symbol	Definition or explanation
Rated torque of coupling	T_{KN}	Torque that can continuously be transmitted over the entire permissible speed range
Maximum torque of coupling	T_{Kmax}	Torque that can be transmitted as dynamic load $\geq 10^3$ times or 5×10^4 as vibratory load, respectively, during the entire operating life of the coupling
Vibratory torque of coupling	T_{KW}	Torque amplitude of the permissible periodical torque fluctuation with a frequency of 10 Hz and a basic load of T_{KN} or dynamic load up to T_{KN} , respectively
Damping power of coupling	P_{KW}	Permissible damping power with an ambient temperature of + 30 °C.
Rated torque of machine	T_N	Stationary rated torque on the coupling
Rated torque of driving side	T_{AN}	Rated torque of machine, calculated from rated power and rated speed
Rated torque of load side	T_{LN}	Maximum figure of the load torque calculated from power and speed
Peak torque of machine	T_S	Peak torque on the coupling
Peak torque on the driving side	T_{AS}	Peak torque with torque shock on the driving side, e. g. breakdown torque of the electric motor

Description	Symbol	Definition or explanation
Peak torque of load side	T_{LS}	Peak torque with torque shock on load side, e. g. braking
Vibratory torque of machine	T_W	Amplitude of the vibratory torque effective on the coupling
Damping power of the machine	P_W	Damping power which is effective on the coupling due to the load produced by the vibratory torque
Moment of inertia of driving side	J_A	Total of moments of inertia existing on the driving or load side referring to the coupling speed
Moment of inertia of load side	J_L	
Rotational inertia coefficient of driving side	M_A	Factor taking into account the mass distribution with shocks and vibrations produced on the driving or load side
Rotational inertia coefficient of load side	M_L	

$$M_A = \frac{J_L}{(J_A + J_L)} \quad M_L = \frac{J_A}{(J_A + J_L)}$$

Permissible load on feather key of the coupling hub

The shaft-hub-connection has to be verified by the customer. Permissible surface pressure according to DIN 6892 (method C).

Cast iron GJL
Stell

225 N/mm²
250 N/mm²

nodular iron GJS

225 N/mm²

Coupling selection

Service factor temperature S_t											
	-50 °C	-30 °C +30 °C	+40 °C	+50 °C	+60 °C	+70 °C	+80 °C	+90 °C	+100 °C	+110 °C	+120 °C
T-PUR®	1,0	1,0	1,1	1,2	1,3	1,45	1,6	1,8	2,1	2,5	3,0
PUR	-	1,0	1,2	1,3	1,4	1,55	1,8	2,2	-	-	-

For the selection with PEEK and spiders from wire a temperature factor is not necessary.
For temperature factors for PA spiders see page 26.

Service factor S_z for starting frequency				
starting frequency/h	100	200	400	800
S_z	1,0	1,2	1,4	1,6

Service factor S_A/S_L for shocks	
	S_A/S_L
gentle shocks	1,5
average shocks	1,8
heavy shocks	2,5

Example of calculation of standard IEC motors shown on page 22:

Given: Details of driving side

A. C. motor type 315 L → $S_A = 1,8$
 Motor output $P = 160$ kW
 Speed $n = 1485$ rpm
 Moment of inertia driven side $J_A = 2,9$ kgm²
 Start-up frequency $z = 6^{1/h}$ → $S_z = 1,0$
 Ambient temperature $= +70$ °C → $S_t = 1,45$ using T-PUR®

Given: Details of load side

Screw compressor
 Rated torque of load side $T_{LN} = 930$ Nm
 Moment of inertia of load side $J_L = 6,8$ kgm²

Calculation

I Rated driving torque

$$T_{AN} \text{ [Nm]} = 9550 \cdot \frac{P_{AN} \text{ [kW]}}{n_{AN} \text{ [rpm]}}$$

$$T_{AN} = 9550 \cdot \frac{160 \text{ kW}}{1485 \text{ rpm}} = 1029 \text{ Nm}$$

Coupling selection:

I Load produced by rated torque

$$T_{KN} \geq T_{LN} \cdot S_t$$

$$T_{KN} \geq 930 \text{ Nm} \cdot 1,45 = 1348,5 \text{ Nm}$$

Selected: ROTEX® Size 90 - spider 92 Shore A with:

$$T_{KN} = 2400 \text{ Nm}$$

$$T_{K \max} = 4800 \text{ Nm}$$

● Load produced by torque shocks

$$T_{K \max} \geq T_S \cdot S_z \cdot S_t$$

$$T_S = T_{AS} \cdot M_A \cdot S_A$$

$$M_A = \frac{J_L}{(J_A + J_L)} = \frac{(6,8 \text{ kgm}^2 + 0,0673 \text{ kgm}^2)}{(2,9 \text{ kgm}^2 + 0,0673 \text{ kgm}^2 + 6,8 \text{ kgm}^2 + 0,0673 \text{ kgm}^2)} = 0,7$$

● Driving torque

$$T_{AS} = 2,0 \cdot T_{AN} = 2,0 \cdot 1029 \text{ Nm} = 2058 \text{ Nm}$$

$$T_S = 2058 \text{ Nm} \cdot 0,7 \cdot 1,8 = 2593,1 \text{ Nm}$$

$$T_{K \max} \geq 2593,1 \text{ Nm} \cdot 1 \cdot 1,45 = 3760 \text{ Nm}$$

$$T_{K \max} \text{ with } 4800 \text{ Nm} \geq 3760 \text{ Nm} \quad \checkmark$$

Displacements

Axial displacement ΔK_a

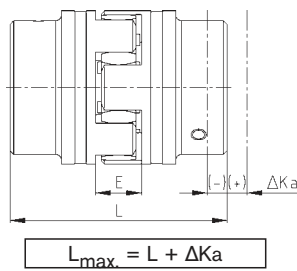

Radial displacement ΔK_r

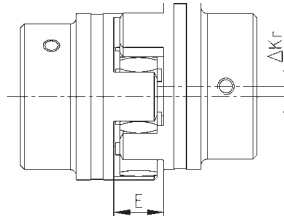

Angular displacement ΔK_w [degrees]

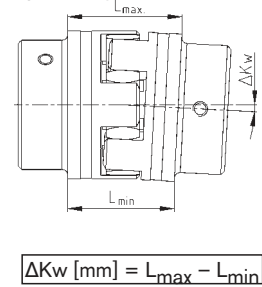

Displacements spider 92, 95/98 Shore-A																	
ROTEX® Size	14	19	24	28	38	42	48	55	65	75	90	100	110	125	140	160	180
Max. axial displacement ΔK_a [mm]	-0,5 +1,0	-0,5 +1,2	-0,5 +1,4	-0,7 +1,5	-0,7 +1,8	-1,0 +2,0	-1,0 +2,1	-1,0 +2,2	-1,0 +2,6	-1,5 +3,0	-1,5 3,4	-1,5 +3,8	-2,0 +4,2	-2,0 +4,6	-2,0 +5,0	-2,5 +5,7	-3,0 +6,4
Max. radial displacement with $n=1500$ rpm ΔK_r [mm]	0,17	0,20	0,22	0,25	0,28	0,32	0,36	0,38	0,42	0,48	0,50	0,52	0,55	0,60	0,62	0,64	0,68
Max. angular displacement with $n=1500$ rpm ΔK_w [degree]	1,2	1,2	0,9	0,9	1,0	1,0	1,1	1,1	1,2	1,2	1,2	1,2	1,3	1,3	1,2	1,2	1,2
ΔK_w [mm]	0,67	0,82	0,85	1,05	1,35	1,70	2,00	2,30	2,70	3,30	4,30	4,80	5,60	6,50	6,60	7,60	9,00

Displacements spider 64 Shore-D																	
ROTEX® Size	14	19	24	38	42	48	55	65	75	90	100	110	125	140	160	180	
Max. axial displacement ΔK_a [mm]	-0,5 +1,0	-0,5 +1,2	-0,5 +1,4	-0,7 +1,5	-0,7 +1,8	-1,0 +2,0	-1,0 +2,1	-1,0 +2,2	-1,0 +2,6	-1,5 +3,0	-1,5 +3,4	-1,5 +3,8	-2,0 +4,2	-2,0 +4,6	-2,0 +5,0	-2,5 +5,7	-3,0 +6,4
Max. radial displacement with $n=1500$ rpm ΔK_r [mm]	0,11	0,13	0,15	0,18	0,21	0,23	0,25	0,27	0,30	0,34	0,36	0,37	0,40	0,43	0,45	0,46	0,49
Max. angular displacement with $n=1500$ rpm ΔK_w [degree]	1,1	1,1	0,8	0,8	0,9	0,9	1,0	1,0	1,1	1,1	1,1	1,1	1,2	1,2	1,1	1,1	1,1
ΔK_w [mm]	0,57	0,76	0,76	0,90	1,25	1,40	1,80	2,00	2,50	3,00	3,80	4,30	5,30	6,00	6,10	7,10	8,00

Displacements spider PA, PEEK and spider from wire																
ROTEX® Size	14	19	24	28	38	42	48	55	65	75	90	100	110	125	140	
Max. axial displacement ΔK_a [mm]	-0,5 +1,0	-0,5 +1,2	-0,5 +1,4	-0,7 +1,5	-0,7 +1,8	-1,0 +2,0	-1,0 +2,1	-1,0 +2,2	-1,0 +2,6	-1,5 +3,0	-1,5 3,4	-1,5 +3,8	-2,0 +4,2	-2,0 +4,6	-2,0 +5,0	
Max. radial displacement with $n=1500$ rpm ΔK_r [mm]	0,08	0,10	0,11	0,12	0,14	0,16	0,18	0,19	0,21	0,24	0,25	0,26	0,27	0,30	0,31	
Max. angular displacement with $n=1500$ rpm ΔK_w [degree]	0,60	0,45	0,45	0,50	0,50	0,55	0,55	0,55	0,60	0,60	0,60	0,60	0,65	0,65	0,60	
ΔK_w [mm]	0,33	0,41	0,42	0,52	0,67	0,85	1,00	1,15	1,35	1,65	2,15	2,40	2,80	3,25	3,30	

The above-mentioned figures of displacement of flexible ROTEX® couplings are standard values taking into account the load of the coupling up to the rated torque T_{KN} and an operating speed $n = 1500$ rpm along with an ambient temperature of $+ 30^\circ C$. For different operating conditions please order our data sheet KTR-N 20240 regarding displacements for ROTEX®. The displacement figures may only be used one by one - if they appear simultaneously, they must be limited in proportion. Care should be taken to maintain the distance dimension E accurately in order to allow for axial clearance of the coupling while in operation. Detailed mounting instructions are shown on our homepage (www.ktr.com).

Selection of standard IEC motors

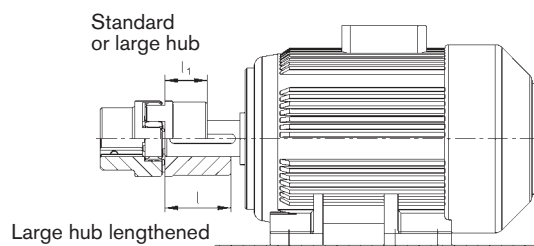

ROTEX® couplings for standard IEC motors, protection IP 54/IP 55 (spider 92 Shore A)													
A. C. motor 50 Hz		Motor output n = 3000 1/min 2-pole		ROTEX® coupling size	Motor output n = 1500 1/min 4-pole		ROTEX® coupling size	Motor output n = 1000 1/min 6-pole		ROTEX® coupling size	Motor output n = 750 1/min 8-pole		ROTEX® coupling size
Size	Shaft end d x l [mm]		Output P [kW]		Torque T [Nm]	Output P [kW]		Torque T [Nm]	Output P [kW]		Torque T [Nm]	Output P [kW]	
	2-pole	4,6,8 pole											
56	9 x 20		0,09	0,32	9 ¹⁾	0,06	0,43	9 ¹⁾	0,037	0,43	9 ¹⁾		
			0,12	0,41		0,09	0,64		0,045	0,52			
63	11 x 23		0,18	0,62	14	0,12	0,88	14	0,06	0,7	14		
			0,25	0,86		0,18	1,3		0,09	1,1			
71	14 x 30		0,37	1,3	14	0,25	1,8	14	0,18	2	14	0,09	1,4
			0,55	1,9		0,37	2,5		0,25	2,8		0,12	1,8
80	19 x 40		0,75	2,5	19	0,55	3,7	19	0,37	3,9	19	0,18	2,5
			1,1	3,7		0,75	5,1		0,55	5,8		0,25	3,5
90S	24 x 50		1,5	5	19	1,1	7,5	19	0,75	8	19	0,37	5,3
90L			2,2	7,4		1,5	10		1,1	12		0,55	7,9
100L	28 x 60		3	9,8	24	2,2	15	24	1,5	15	24	0,75	11
						3	20					1,1	16
112M			4	13	24	4	27	24	2,2	22	24	1,5	21
132S			5,5	18								3	30
132M	38 x 80		7,5	25	28	5,5	36	28	4	40	28	3	40
						7,5	49					5,5	55
160M	42 x 110		11	36	38	11	72	38	7,5	75	38	4	54
			15	49								11	109
160L			18,5	60	38	15	98	38	11	109	38	7,5	100
180M	48 x 110		22	71			18,5		121				
180L					42	22	144	42	15	148	42	11	145
						30	196			18,5		181	
200L	55 x 110		30	97	42	30	196	42	22	215	42		
			37	120									
225S	55 x 110				48	37	240	48			48	18,5	244
225M	60 x 140		45	145			45		292			30	293
250M	60 x 140	65 x 140	55	177	55	55	356	55	37	361	55	30	392
280S	75 x 140		75	241			75		484			45	438
280M			90	289	55	90	581	55	55	535	55	45	587
315S			110	353			110		707			75	727
315M	80 x 170		132	423	65	132	849	65	90	873	65	75	971
			160	513			160		1030			110	1070
315L	65 x 140		200	641	75	200	1290	75	132	1280	75	110	1420
										160		1550	
315	85 x 170		250	802	75	250	1600	75	200	1930	75	160	2070
			315	1010			315		2020			250	2410
355	75 x 140	95 x 170	355	1140	90	355	2280	90			90	200	2580
			400	1280			400		2570			315	3040
			500	1600	90	500	3210	90	400	3850	90	315	4060
			560	1790			560		3580			450	4330
400	80 x 170	110 x 210	630	2020	100	630	4030	100	500	4810	100	400	5150
			710	2270			710		4540			560	5390
			800	2560	110	800	5120	110	630	6060	110	500	6420
450	90 x 170	120 x 210	900	2880			900		5760			710	6830
			1000	3200		1000	6400		800	7690		630	8090

The arrangement of couplings is valid for an ambient temperature of up to + 30 °C. For the selection there is a minimum safety factor of 2 of the max. coupling torque (T_{Kmax}).



A detailed arrangement is possible according to catalogue, page 20 and 21. Drives with periodical torque curves must be selected according to DIN 740 part 2. If requested, KTR will make the selection.



Torque T = nominal torque according to Siemens catalogue M 11 · 1994/95.

¹⁾ For dimensions see ROTEX® GS line

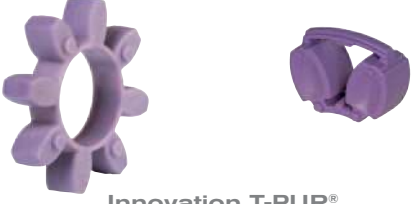

²⁾ Motor hub from steel see page 31

Properties of our standard spiders

Spider type (hardness shore)	92 Shore-A (T-PUR®)	DZ 92 Shore-A (T-PUR®)	92 Shore-A
	 <p style="text-align: center;">Innovation T-PUR®</p>		
Size	14 to 90	100 to 180	14 to 90
Material	T-PUR®		Polyurethane (PUR)
Perm. temperature range	-50 °C to +120 °C		-40 °C to +90 °C
Continuous temperature	-50 °C to +150 °C		-50 °C to +120 °C
Max. temperature short time			
Properties	<ul style="list-style-type: none"> - significantly longer service life - very good temperature resistance - improved damping of vibrations - good damping, average elasticity - suitable for all hub materials 		<ul style="list-style-type: none"> - good damping, average elasticity - suitable for all hub materials

Spider type (hardness shore)	98 Shore-A (T-PUR®) ¹⁾	DZ 95 Shore-A (T-PUR®)	98 Shore-A ¹⁾
	 <p style="text-align: center;">Innovation T-PUR®</p>		
Size	14 to 90	100 to 180	14 to 90
Material	T-PUR®		Polyurethane (PUR)
Perm. temperature range	-50 °C to +120 °C		-30 °C to +90 °C
Continuous temperature	-50 °C to +150 °C		-40 °C to +120 °C
Max. temperature short time			
Properties	<ul style="list-style-type: none"> - significantly longer service life - very good temperature resistance - improved damping of vibrations - transmission of high torques with average damping - recommended hub material: Steel, GJL and GJS 		<ul style="list-style-type: none"> - transmission of high torques with average damping - recommended hub material: Steel, GJL and GJS

¹⁾ up to size 65: 95 Sh-A

Spider type (hardness shore)	64 Shore-D (T-PUR®)	DZ 64 Shore-D (T-PUR®)	64 Shore-D
	 <p style="text-align: center;">Innovation T-PUR®</p>		
Size	14 to 90	100 to 180	14 to 90
Material	T-PUR®		Polyurethane (PUR)
Perm. temperature range	-50 °C to +120 °C		-30 °C to +110 °C
Continuous temperature	-50 °C to +150 °C		-30 °C to +130 °C
Max. temperature short time			
Properties	<ul style="list-style-type: none"> - significantly longer service life - very good temperature resistance - improved damping of vibrations - transmission of very high torques with low damping - recommended hub material: Steel and GJS 		<ul style="list-style-type: none"> - transmission of very high torques with low damping - suitable for displacing critical speeds - resistant to hydrolysis - recommended hub material: Steel and GJS

ROTEX® 14

ROTEX® 19

ROTEX® 24 - 65

ROTEX® 75 - 160

ROTEX® 180

ROTEX® DZ 100 - 160

ROTEX® DZ 180

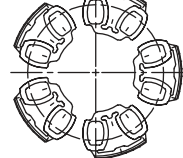
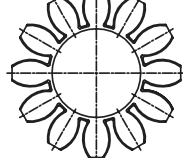
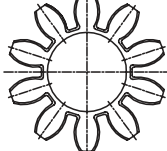
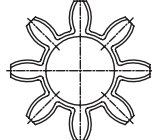
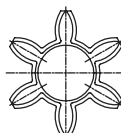
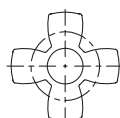

Technical data of our standard spiders

Spider 92 Shore-A made from T-PUR® and PUR														
ROTEX® Size	Max. speed		Twist angle ϕ with		Torque [Nm]			Damping power P _{KW} [W] ¹⁾	Relative Damping ψ	Resonance factor V _R	Torsion spring stiffness C dyn. [Nm/rad]			
	V=35 m/s iron	V=40 m/s steel	T _{KN}	T _{K max}	Rated (TKN)	Max (TK max)	Vibratory (TKW)				1,0 T _{KN}	0,75 T _{KN}	0,5 T _{KN}	0,25 T _{KN}
14	22200	25400	6,4°	10°	7,5	15	2,0	–			0,38x10 ³	0,31x10 ³	0,24x10 ³	0,14x10 ³
19	16700	19000			10	20	2,6	4,8			1,28x10 ³	1,05x10 ³	0,80x10 ³	0,47x10 ³
24	12100	13800			35	70	9,1	6,6			4,86x10 ³	3,98x10 ³	3,01x10 ³	1,79x10 ³
28	10100	11500			95	190	25	8,4			10,90x10 ³	8,94x10 ³	6,76x10 ³	4,01x10 ³
38	8300	9500			190	380	49	10,2			21,05x10 ³	17,26x10 ³	13,05x10 ³	7,74x10 ³
42	7000	8000			265	530	69	12,0			23,74x10 ³	19,47x10 ³	14,72x10 ³	8,73x10 ³
48	6350	7250			310	620	81	13,8			36,70x10 ³	30,09x10 ³	22,75x10 ³	13,49x10 ³
55	5550	6350			410	820	107	15,6			50,72x10 ³	41,59x10 ³	31,45x10 ³	18,64x10 ³
65	4950	5650	3,2°	5°	625	1250	163	18,0	0,80	7,90	97,13x10 ³	79,65x10 ³	60,22x10 ³	35,70x10 ³
75	4150	4750			1280	2560	333	21,6			113,32x10 ³	92,92x10 ³	70,26x10 ³	41,65x10 ³
90	3300	3800			2400	4800	624	30,0			190,09x10 ³	155,87x10 ³	117,86x10 ³	69,86x10 ³
100	2950	3350			3300	6600	858	36,0			253,08x10 ³	207,53x10 ³	156,91x10 ³	93,01x10 ³
110	2600	2950			4800	9600	1248	42,0			311,61x10 ³	255,52x10 ³	193,20x10 ³	114,52x10 ³
125	2300	2600			6650	13300	1729	48,0			474,86x10 ³	389,39x10 ³	294,41x10 ³	174,51x10 ³
140	2050	2350			8550	17100	2223	54,6			660,49x10 ³	541,60x10 ³	409,50x10 ³	242,73x10 ³
160	1800	2050			12800	25600	3328	75,0			890,36x10 ³	730,10x10 ³	552,03x10 ³	327,21x10 ³
180	1550	1800			18650	37300	4849	78,0			2568,56x10 ³	2106,22x10 ³	1592,51x10 ³	943,95x10 ³

Spider 95/98 Shore-A made from T-PUR® and PUR														
ROTEX® Size	Max. speed		Twist angle ϕ with		Torque [Nm]			Damping power P _{KW} [W] ¹⁾	Relative Damping ψ	Resonance factor V _R	Torsion spring stiffness C dyn. [Nm/rad]			
	V=35 m/s iron	V=40 m/s steel	T _{KN}	T _{K max}	Rated (TKN)	Max (TK max)	Vibratory (TKW)				1,0 T _{KN}	0,75 T _{KN}	0,5 T _{KN}	0,25 T _{KN}
14	22200	25400	6,4°	10°	12,5	25	3,3	–			0,56x10 ³	0,46x10 ³	0,35x10 ³	0,21x10 ³
19	16700	19000			17	34	4,4	4,8			2,92x10 ³	2,39x10 ³	1,81x10 ³	1,07x10 ³
24	12100	13800			60	120	16	6,6			9,93x10 ³	8,14x10 ³	6,16x10 ³	3,65x10 ³
28	10100	11500			160	320	42	8,4			26,77x10 ³	21,95x10 ³	16,60x10 ³	9,84x10 ³
38	8300	9500			325	650	85	10,2			48,57x10 ³	39,83x10 ³	30,11x10 ³	17,85x10 ³
42	7000	8000			450	900	117	12,0			54,50x10 ³	44,69x10 ³	33,79x10 ³	20,03x10 ³
48	6350	7250			525	1050	137	13,8			65,29x10 ³	53,54x10 ³	40,48x10 ³	24,00x10 ³
55	5550	6350			685	1370	178	15,6			94,97x10 ³	77,88x10 ³	58,88x10 ³	34,90x10 ³
65	4950	5650	3,2°	5°	940	1880	244	18,0	0,80	7,90	129,51x10 ³	106,20x10 ³	80,30x10 ³	47,60x10 ³
75	4150	4750			1920	3840	499	21,6			197,50x10 ³	161,95x10 ³	122,45x10 ³	72,58x10 ³
90	3300	3800			3600	7200	936	30,0			312,20x10 ³	256,00x10 ³	193,56x10 ³	114,73x10 ³
100	2950	3350			4950	9900	1287	36,0			383,26x10 ³	314,27x10 ³	237,62x10 ³	140,85x10 ³
110	2600	2950			7200	14400	1872	42,0			690,06x10 ³	565,85x10 ³	427,84x10 ³	253,60x10 ³
125	2300	2600			10000	20000	2600	48,0			1343,64x10 ³	1101,79x10 ³	833,06x10 ³	493,79x10 ³
140	2050	2350			12800	25600	3328	54,6			1424,58x10 ³	1168,16x10 ³	883,24x10 ³	523,54x10 ³
160	1800	2050			19200	38400	4992	75,0			2482,23x10 ³	2035,43x10 ³	1538,98x10 ³	912,22x10 ³
180	1550	1800			28000	56000	7280	78,0			3561,45x10 ³	2920,40x10 ³	2208,10x10 ³	1308,84x10 ³

Spider 64 Shore-D made from T-PUR® and PUR														
ROTEX® Size	Max. speed		Twist angle ϕ with		Torque [Nm]			Damping power P _{KW} [W] ¹⁾	Relative Damping ψ	Resonance factor V _R	Torsion spring stiffness C dyn. [Nm/rad]			
	V=35 m/s iron	V=40 m/s steel	T _{KN}	T _{K max}	Rated (TKN)	Max (TK max)	Vibratory (TKW)				1,0 T _{KN}	0,75 T _{KN}	0,5 T _{KN}	0,25 T _{KN}
14	22200	25400	4,5°	7,0°	16	32	4,2	9,0			0,76x10 ³	0,62x10 ³	0,47x10 ³	0,28x10 ³
19 ²⁾	16700	19000			21	42	5,5	7,2			5,35x10 ³	4,39x10 ³	3,32x10 ³	1,97x10 ³
24	12100	13800			75	150	19,5	9,9			15,11x10 ³	12,39x10 ³	9,37x10 ³	5,55x10 ³
28	10100	11500			200	400	52	12,6			27,52x10 ³	22,57x10 ³	17,06x10 ³	10,12x10 ³
38	8300	9500			405	810	105	15,3			70,15x10 ³	57,52x10 ³	43,49x10 ³	25,78x10 ³
42	7000	8000			560	1120	146	18,0			79,86x10 ³	65,49x10 ³	49,52x10 ³	29,35x10 ³
48	6350	7250			655	1310	170	20,7			95,51x10 ³	78,32x10 ³	59,22x10 ³	35,10x10 ³
55	5550	6350			825	1650	215	23,4			107,92x10 ³	88,50x10 ³	66,91x10 ³	39,66x10 ³
65	4950	5650	2,5°	3,6°	1175	2350	306	27,0	0,75	8,50	151,09x10 ³	123,90x10 ³	93,68x10 ³	55,53x10 ³
75	4150	4750			2400	4800	624	32,4			248,22x10 ³	203,54x10 ³	153,90x10 ³	91,22x10 ³
90	3300	3800			4500	9000	1170	45,0			674,52x10 ³	553,11x10 ³	418,20x10 ³	247,89x10 ³
100	2950	3350			6185	12370	1608	54,0			861,17x10 ³	706,16x10 ³	533,93x10 ³	316,48x10 ³
110	2600	2950			9000	18000	2340	63,0			1138,59x10 ³	933,64x10 ³	705,92x10 ³	418,43x10 ³
125	2300	2600			12500	25000	3250	72,0			1435,38x10 ³	1177,01x10 ³	889,93x10 ³	527,50x10 ³
140	2050	2350			16000	32000	4160	81,9			1780,73x10 ³	1460,20x10 ³	1104,05x10 ³	654,42x10 ³
160	1800	2050			24000	48000	6240	112,5			3075,80x10 ³	2522,16x10 ³	1907,00x10 ³	1130,36x10 ³
180	1550	1800			35000	70000	9100	117,0			6011,30x10 ³	4929,27x10 ³	3727,01x10 ³	2209,15x10 ³



Temperature factor S _t											
	-50 °C	-30 °C +30 °C	+40 °C	+50 °C	+60 °C	+70 °C	+80 °C	+90 °C	+100 °C	+110 °C	+120 °C
T-PUR®	1,0	1,0	1,1	1,2	1,3	1,45	1,6	1,8	2,1	2,5	3,0
PUR	–	1,0	1,2	1,3	1,4	1,55	1,8	2,2	–	–	–

Unless explicitly specified in your order, we will supply spiders with Shore hardness 92 Sh-A T-PUR®. For circumferential speeds exceeding V = 30 m/s dynamic balancing is necessary. For circumferential speeds exceeding V = 35 m/s only steel or nodular iron.

¹⁾ with +30 °C

²⁾ only as 64Sh-D-H

Technical data and properties of the special spiders

			
Spider type	PA	PEEK	Spider from wire
Material	Polyamide	Polyetheretherketone	stainless steel
Perm. temperature range			
Continuous temperature	-20°C to +130 °C ¹⁾	to +180 °C (ATEX to +160 °C)	to +250 °C
Max. temperature short time	-30 °C to +150 °C ¹⁾	to +250 °C	-
Properties	<ul style="list-style-type: none"> - low twisting angles and high torsion spring stiffness - transmission of very high torques with very low damping - very good to good resistance to chemicals ¹⁾ - recommended hub material: Steel - high restoring forces with displacements 	<ul style="list-style-type: none"> - low twisting angles and high torsion spring stiffness - transmission of very high torques with very low damping - highly temperature resistant, resistant to hydrolysis - good to good resistance to chemicals - recommended hub material: Steel - high restoring forces with displacements 	<ul style="list-style-type: none"> - transmission of high torques with average damping - highly temperature resistant, resistant to hydrolysis - very good to good resistance to chemicals - recommended hub material: Steel, GJL and hard coated ALU

¹⁾ Different properties depending on compound

Torques					
ROTEX® Size	PA, PEEK			Spider from wire	
	T _{KN} [Nm]	T _{K max} [Nm]	T _{KW} [Nm]	T _{KN} [Nm]	T _{K max} [Nm]
14	22	44	5,5	7,5	15
19	30	60	8,0	10	20
24	105	210	27,5	35	70
28	280	560	73	95	380
38	565	1130	147	190	530
42	785	1570	204	265	620
48	915	1830	238	310	620
55	1200	2400	312	410	820
65	1645	3290	427	-	-
75	2560	5130	667	-	-
90	6300	12600	1640	-	-
100	8650	17300	2250	-	-
110	10500	21000	2730	-	-
125	13000	26000	3380	-	-

Service factor temperature S _t												
	-50 °C	-30 °C +30 °C	+40 °C	+50 °C	+60 °C	+70 °C	+80 °C	+90 °C	+100 °C	+110 °C	+120 °C	+180 °C
PA	-	1,0	1,15	1,25	1,4	1,6	1,9	2,3	3,0	-	-	-
PEEK	-	1,0	1,0	1,0	1,0	1,0	1,0	1,0	1,0	1,0	1,0	1,0
Spider from wire	-	1,0	1,0	1,0	1,0	1,0	1,0	1,0	1,0	1,0	1,0	1,0

Installation spider

Shaft with keyway (acc. DIN 6885 sh.1) protruding into the spider $\varnothing d_W$

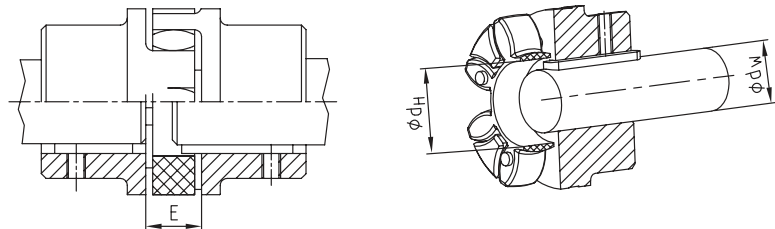

Mounting dimension																	
ROTEX® Size	14	19	24	28	38	42	48	55	65	75	90	100	110	125	140	160	180
Distance dimension E	13	16	18	20	24	26	28	30	35	40	45	50	55	60	65	75	85
Dimension d _H	10	18	27	30	38	46	51	60	68	80	100	113	127	147	165	190	220
Dimension d _W ²⁾	7	12	20	22	28	36	40	48	55	65	80	95	100	120	135	160	185

²⁾ If the shaft diameter is smaller than or corresponds to the dimension d_H, one shaft end or both shaft ends may protrude with the feather key in the spider.

Hub designs

Due to the numerous applications of ROTEX® for many different mounting situations, this coupling system is available with various hub designs. These designs mainly differ in that they offer either positive or frictionally engaged connections, but mounting situations like, for example, gear shafts with integrated transmission cams or similar applications are covered, too.

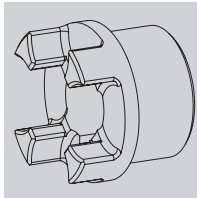

Design 1.0 hub with keyway and fixing screw

Positive locking power transmission, permissible torque depending on the permissible surface pressure. Not suitable for backlash-free power transmission with heavily reversing operation.

Design 1.1 hub without keyway, with fixing screw

Non-positive torque transmission for crimp and glued connections (no ATEX release).

Design 1.3 hub spline bore (page 28)

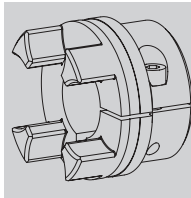

Design 2.0 clamping hub, single slotted, without keyway

Frictionally engaged, backlash-free shaft-hub-connection. Transmittable torques depending on bore diameter (see page 34). (For ATEX category 3 only).

Design 2.1 clamping hub, single slotted, with keyway

Positive locking power transmission with additional frictionally engaged condition. The frictionally engaged condition prevents or reduces reverse backlash, respectively. Surface pressure of the feather key connection is prevented.

Design 2.3 clamping hub with spline bore (page 28/34)

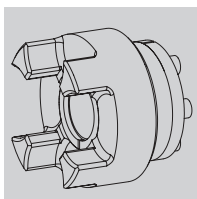

Design 4.2 with CLAMPEX® clamping set KTR 250

Frictionally engaged, backlash-free shaft-hub-connection for the transmission of average torques.

Design 4.1 with CLAMPEX® clamping set KTR 200

Design 4.3 with CLAMPEX® clamping set KTR 400

Frictionally engaged, backlash-free shaft-hub-connection for the transmission of high torques.

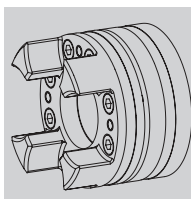

Design 6.0 clamping ring hub (see ROTEX® GS series)

Integrated frictionally engaged shaft-hub-connection for the transmission of higher torques. Screwing on elastomer side. For details about torque and dimensions see page 33. Suitable for high speeds.

Design 6.5 clamping ring hub (see ROTEX® GS series)

Design like 6.0, except for clamping screws externally. As an example for radial assembly of intermediate pipe (special design).

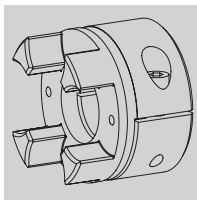

Design 7.5 shell clamping hub without feather key for a double-cardanic connection

Frictionally engaged, backlash-free shaft-hub-connection for radial assembly of coupling. Transmittable torques depending on bore diameter (for ATEX category 3 only).

Design 7.6 shell clamping hub with feather key for a double-cardanic connection

Positive locking power transmission with additional frictionally engaged condition for radial assembly of coupling. The frictionally engaged condition prevents or reduces reverse backlash, respectively. Surface pressure of the feather key connection is prevented.

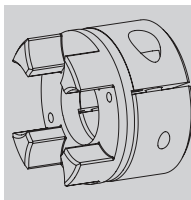

Design 7.8 shell clamping hub without feather key

Frictionally engaged, backlash-free shaft-hub-connection for radial assembly of coupling. Transmittable torques depend on the bore diameter (for ATEX category 3 only).

Design 7.9 shell clamping hub with feather key

Positive locking power transmission with additional backlash for radial assembly of coupling. The frictionally engaged condition prevents or reduces backlash, respectively. Surface pressure of the feather key is prevented.

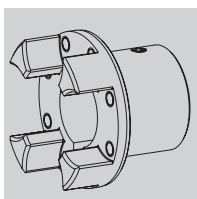

FNN hub

Coupling hub to be connected to an attachment such as brake drum, brake disk and fan.

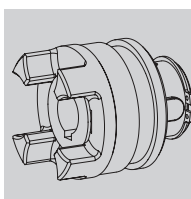

SD hub shifting hub

Coupling hub for separating or switching on the driving/driven machine with standstill of the machine. Can be combined with slip ring and shiftable linkage.

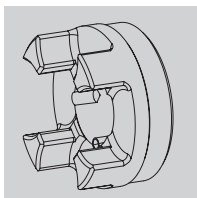

TB1 hub/TB2 hub

Coupling hub for taper clamping bushes. TB1 screwed on cam side. TB2 screwed externally.

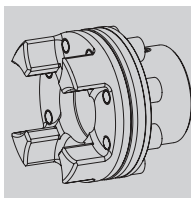

Design 3Na + 4N Driving flange with coupling flange

For type AFN and BFN. With type AFN the spider can be replaced while being assembled without having to disassemble the driving and driven side.

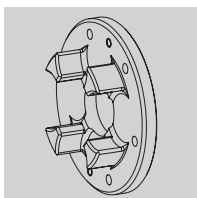

Driving flange design 3b

Driving flange to connect to customer's component. For dimensions see page 37.

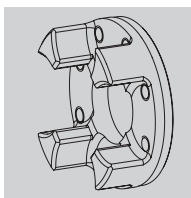

Driving flange design 3Na

Driving flange to connect to customer's component. For dimensions see page 37.

Cylindrical bores and spline bores

		Stock programme cylindrical finish bore [mm] H7 keyway to DIN 6885 sheet 1 [JS9] with thread for setscrew																																					
ROTEX® Size/material	un- bored	Ø6	Ø8	Ø9	Ø10	Ø11	Ø12	Ø14	Ø15	Ø16	Ø17	Ø18	Ø19	Ø20	Ø22	Ø24	Ø25	Ø28	Ø30	Ø32	Ø35	Ø38	Ø40	Ø42	Ø45	Ø48	Ø50	Ø55	Ø60	Ø65	Ø70	Ø75	Ø80	Ø85	Ø90	Ø100			
14	Sint	●	●	●	●	●	●	●	●	●																													
	Al-H	●	●	●	●	●	●	●	●	●																													
19	Sint	●																																					
	AL-D	●	●	●	●	●	●	●	●	●	●	●	●	●	●	●	●	●	●	●	●	●	●	●	●	●	●	●	●	●	●	●	●	●	●	●	●	●	
	St	●	●	●	●	●	●	●	●	●	●	●	●	●	●	●	●	●	●	●	●	●	●	●	●	●	●	●	●	●	●	●	●	●	●	●	●	●	
24	Al-D	●																																					
	St	●	●	●	●	●	●	●	●	●	●	●	●	●	●	●	●	●	●	●	●	●	●	●	●	●	●	●	●	●	●	●	●	●	●	●	●	●	
28	Al-D	●																																					
	St	●	●	●	●	●	●	●	●	●	●	●	●	●	●	●	●	●	●	●	●	●	●	●	●	●	●	●	●	●	●	●	●	●	●	●	●	●	
38	GJL	●																																					
	St	●	●	●	●	●	●	●	●	●	●	●	●	●	●	●	●	●	●	●	●	●	●	●	●	●	●	●	●	●	●	●	●	●	●	●	●	●	
42	GJL	●																																					
	St	●	●	●	●	●	●	●	●	●	●	●	●	●	●	●	●	●	●	●	●	●	●	●	●	●	●	●	●	●	●	●	●	●	●	●	●	●	
48	GJL	●																																					
	St	●	●	●	●	●	●	●	●	●	●	●	●	●	●	●	●	●	●	●	●	●	●	●	●	●	●	●	●	●	●	●	●	●	●	●	●	●	●
55	GJL	●																																					
	St	●	●	●	●	●	●	●	●	●	●	●	●	●	●	●	●	●	●	●	●	●	●	●	●	●	●	●	●	●	●	●	●	●	●	●	●	●	●
65	GJL	●																																					
	St	●	●	●	●	●	●	●	●	●	●	●	●	●	●	●	●	●	●	●	●	●	●	●	●	●	●	●	●	●	●	●	●	●	●	●	●	●	●
75	GJL	●																																					
	St	●	●	●	●	●	●	●	●	●	●	●	●	●	●	●	●	●	●	●	●	●	●	●	●	●	●	●	●	●	●	●	●	●	●	●	●	●	●
90	GJL	●																																					
	St	●	●	●	●	●	●	●	●	●	●	●	●	●	●	●	●	●	●	●	●	●	●	●	●	●	●	●	●	●	●	●	●	●	●	●	●	●	●

GG = EN-GJL-250

Basic programme SAE involute spline											
Spline code	Size	Pitch circle	Pitch	No. of teeth	Angle	Spline code	Size	Pitch circle	Pitch	No. of teeth	Angle
PH-S	5/8"	14,28	16/32	9	30°	PS-S	1 1/2"	35,98	12/24	17	30°
PI-S	3/4"	17,46	16/32	11	30°	PD-S	1 1/2"	36,51	16/32	23	30°
PB-S	7/8"	20,63	16/32	13	30°	PE-S	1 3/4"	42,86	16/32	27	30°
PB-BS	1"	23,81	16/32	15	30°	PK	1 3/4"	41,275	8/16	13	30°
PJ	1 1/8"	26,98	16/32	17	30°	PT-C ¹⁾	2"	47,625	8/16	15	30°
PC-S	1 1/4"	29,63	12/24	14	30°	PQ-C ¹⁾	2 1/4"	53,975	8/16	17	30°
PA-S	1 3/8"	33,33	16/32	21	30°						

Basic programme spline bores to DIN 5482									
Size	Pitch circle	Pitch	No. of teeth	Profile correctio	Size	Pitch circle	Pitch	No. of teeth	Profile correction
A 17 x 14	14,40	1,6	9	+0,600 ²⁾	A 35 x 31	31,50	1,75	18	+0,676
A 20 x 17	19,20	1,6	12	-0,2	A 40 x 36	38,00	1,9	20	+0,049
A 25 x 22	22,40	1,6	14	+0,550	A 45 x 41	44,00	2	22	+0,181
A 28 x 25	26,25	1,75	15	+0,302	A 50 x 45	48,00	2	24	+0,181
A 30 x 27	28,00	1,75	16	+0,327					

Basic programme spline bores to DIN 5480							
Spline code	Pitch circle	Module	No. of teeth	Spline code	Pitch circle	Module	No. of teeth
20 x 1 x 18 x 7H	18,0	1	18	40 x 2 x 18 x 7H	36,0	2	18
20 x 1,25 x 14 x 7H	17,5	1,25	14	45 x 2 x 21 x 7H	41,0	2	21
25 x 1,25 x 18 x 7H	22,5	1,25	18	48 x 2 x 22 x 9H	44,0	2	22
28 x 1,25 x 21 x 7H	26,25	1,25	21	50 x 2 x 24 x 7H	48,0	2	24
30 x 2 x 14 x 7H	26,0	2	14	60 x 2 x 28 x 8H	56,0	2	28
32 x 2 x 14 x 8H	28,0	2	14	75 x 3 x 24 x 7H	72,0	3	24
35 x 2 x 16 x 8H	32,0	2	16	80 x 3 x 25 x 8H	75,0	3	25

Basic programme spline bores to DIN 9611				
Size	Width of keyway	No. of teeth	Tip circle	Root circle
1 3/8"	8,69	6	34,93	29,65

Spline clamping hubs are often adapted to the shafts of hydraulic pumps/hydraulic motors. Please ask us about the corresponding hub length of the spline code!

¹⁾ For clamping hubs only, for plug-in hubs use code PT or PQ.

²⁾ spline correction different with DIN

Inch bores and taper bores

ROTEX® Size					Stock programme inch bores									
Material					19	24	28	38	42	48	55	65	75	90
Code	Ød	Ød Inch	b ^{+0.05}	t ₂ ^{+0.2}	St	St	St	GJL	GJL	GJL	GJL	GJL	GJL	GJL
Tb	9,5 ^{+0.03}	3/8	3,17	11,1										
DNB	11,11 ^{M7}	7/16	2,4	12,5										
T	12,69 ^{H7}	1/2	4,75	14,6										
Ta	12,7 ^{+0.03}	1/2	3,17	14,3	●	●								
DNC	13,45 ^{H7}	1 7/32	3,17	14,9										
Do	14,29 ^{+0.03}	9/16	3,17	15,6										
E	15,87 ^{+0.03}	5/8	3,17	17,5										
Es	15,88 ^{+0.03}	5/8	4,00	17,7	●	●	●							
Ed	15,87 ^{+0.03}	5/8	4,75	18,1	●	●								
DNH	17,465 ^{H7}	1 1/16	4,75	19,6										
Ad	19,02 ^{+0.03}	3/4	3,17	20,7										
A	19,05 ^{+0.03}	3/4	4,78	21,3	●	●	●	●						
Gs	22,22 ^{+0.03}	7/8	4,78	24,4	●									
G	22,22 ^{+0.03}	7/8	4,75	24,7	●	●	●	●	●					
F	22,22 ^{+0.03}	7/8	6,38	25,2		●	●	●	●	●				
Gd	22,225 ^{M7}	7/8	4,76	24,7		●								
Gf	23,80 ^{+0.03}	1 5/16	6,35	26,8										
Bs	25,38 ^{+0.03}	1	6,37	28,3		●	●	●	●					
H	25,40 ^{+0.03}	1	4,78	27,8										
Hs	25,40 ^{+0.03}	1	6,35	28,7			●							
R	26,95 ^{+0.03}	1 1/16	4,78	29,3										
Sa	28,575 ^{M7}	1 1/8	6,35	31,7	●	●								
Sb	28,58 ^{+0.03}	1 1/8	6,35	31,5		●	●	●						
Sd	28,58 ^{+0.03}	1 1/8	7,93	32,1										
Js	31,75 ^{+0.03}	1 1/4	6,35	34,6										
K	31,75 ^{K7}	1 1/4	7,93	35,5				●	●	●	●	●		
Ma	34,925 ^{M7}	1 3/8	7,93	38,7		●								
RH1	34,93 ^{M7}	1 3/8	9,55	37,8										
Cb	36,50 ^{+0.03}	1 7/16	9,55	40,9										
Ca	38,07 ^{+0.03}	1 1/2	7,93	42,0										
C	38,07 ^{+0.03}	1 1/2	9,55	42,5			●	●	●	●	●	●	●	
Nb	41,275 ^{M7}	1 5/8	9,55	45,8				●	●					
Ls	44,42 ^{+0.03}	1 3/4	9,55	48,8										
L	44,45 ^{K7}	1 3/4	11,11	49,4										
Lu	47,625 ^{M7}	1 7/8	12,7	53,5					●	●				
Da	49,20 ^{+0.03}	1 5/16	12,7	55,0										
Ds	50,77 ^{+0.03}	2	12,7	56,4										
D	50,80 ^{+0.03}	2	12,7	55,1										
Pa	53,975 ^{M7}	2 1/8	12,7	60,0										
U	57,10 ^{+0.03}	2 1/4	12,7	62,9										
Ub	60,325 ^{M7}	2 3/8	15,875	67,6										
Wd	85,725 ^{M7}	3 3/8	22,225	95,8										
Wf	92,075 ^{M7}	3 5/8	22,225	101,9										

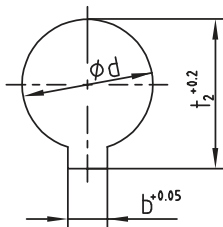

Basic programme taper 1:8					
Code	d ^{+0.05}	(d ₂)	b ^{S9}	t ₂ ^{+0.1}	l _K
...N.../ 1	9,7	7,575	2,4	10,85	17,0
...N.../ 1c	11,6	9,5375	3	12,90	16,5
...N.../ 1e	13,0	10,375	2,4	13,80	21,0
...N.../ 1d	14,0	11,813	3	15,50	17,5
...N.../ 1b	14,3	11,8625	3,2	15,65	19,5
...N.../ 2	17,287	14,287	3,2	18,24	24,0
...N.../ 2a	17,287	14,287	4	18,94	24,0
...N.../ 2b	17,287	14,287	3	18,34	24,0
...N.../ 3	22,002	18,502	4	23,40	28,0
...N.../ 4	25,463	20,963	4,78	27,83	36,0
...N.../ 4b	25,463	20,963	5	28,23	36,0
...N.../ 4a	27,0	22,9375	4,78	28,80	32,5
...N.../ 4g	28,45	23,6375	6	29,32	38,5
...N.../ 5	33,176	27,676	6,38	35,39	44,0
...N.../ 5a	33,176	27,676	7	35,39	44,0
Basic programme taper 1:10					
Code	d	(d ₂)	b	t ₂	l _K
CX	19,95	16,75	5	22,08	32
DX	24,95	20,45	6	26,68	45
EX	29,75	24,75	8	31,88	50

Basic programme taper 1:5					
Code	d ^{+0.05}	(d ₂)	b ^{S9}	t ₂ ^{+0.1}	l _K
A-10	9,85	7,55	2	1,0	11,5
B-17	16,85	13,15	3	1,8	18,5
C-20	19,85	15,55	4	2,2	21,5
Cs-22	21,95	17,65	3	1,8	21,5
D-25	24,85	19,55	5	2,9	26,5
E-30	29,85	23,55	6	2,6	31,5
F-35	34,85	27,55	6	2,6	36,5
G-40	39,85	32,85	6	2,6	35,0

With codes N.../6 and N.../6a parallel to taper the respective pump code should be started before ...N and the respective size of coupling before and behind ...N.../.

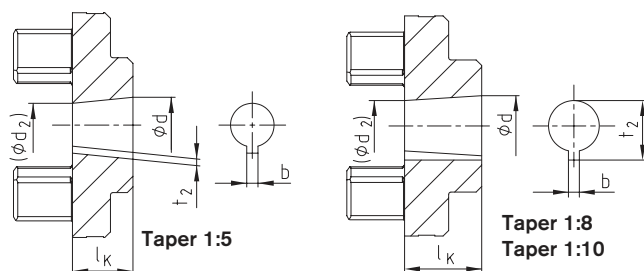

Shaft coupling design No. 001 - casted materials

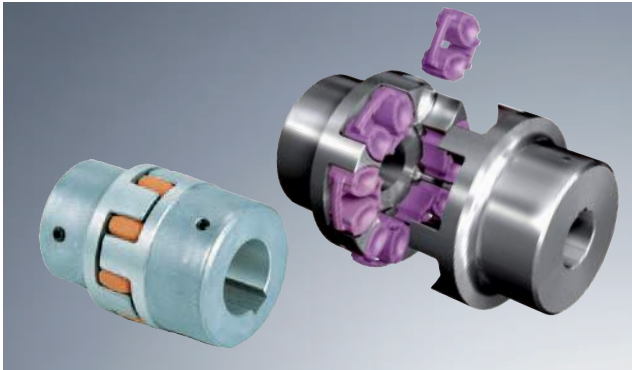

- Torsionally flexible, maintenance-free
- Damping vibrations
- Axial plug-in, fail-safe
- All-over machining – good dynamic properties
- Compact design/small flywheel effect
- Finish bore according to ISO fit H7, feather keyway according to DIN 6885 sheet 1 - JS9
- Stock programme/basic programme see pages 28 and 29
- Approved according to EC Standard 94/9/EC (without aluminium AL-D)
- Mounting instructions under www.ktr.com

Components

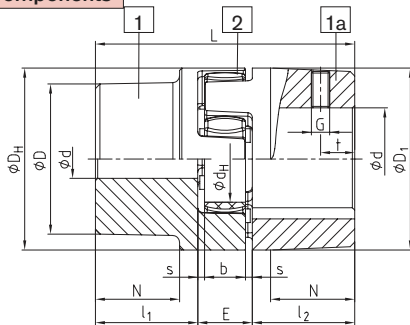

AL-D (thread opposite the keyway)

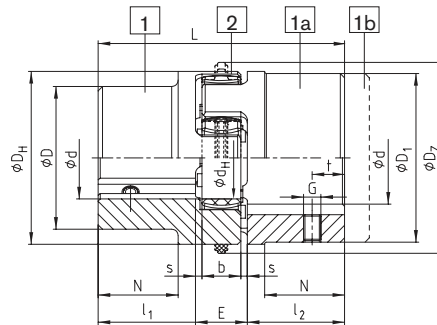

GJL / GJS (thread on the keyway)

Spider
as hardness 92 Sh-A and 95/98 Sh-A standard from size 14 - 90 and 64 Sh-D size 14 - 180

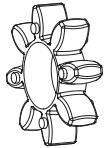

elements DZ (double tooth elements)
as hardness 92 Sh-A and 95 Sh-A standard from size 100 - 180

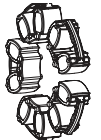

ROTEX® Aluminium diecast (AI-D)

Size	Component	Spider (part 2) ¹⁾			Finish bore d (min-max)	Dimensions [mm]												
		Rated torque [Nm]				General								Thread for setscrews				
		92 Sh-A	98 Sh-A	64 Sh-D		L	l ₁ ; l ₂	E	b	s	D _H	D _Z	d _H	D; D ₁	N	G	t	T _A [Nm]
14 ²⁾	1a	7,5	12,5	-	6-16	35	11	13	10	1,5	30	-	10	30	-	M4	5	1,5
19	1	10	17	-	6-19	66	25	16	12	2	41	-	18	32	20	M5	10	2
	19-24				41													
24	1	35	60	-	9-24	78	30	18	14	2	56	-	27	40	24	M5	10	2
	22-28				56													
28	1	95	160	-	10-28	90	35	20	15	2,5	66	-	30	48	28	M8	15	10
	28-38				66													

ROTEX® Cast iron (GJL)

38	1	190	325	405	12-40	114	45	24	18	3	80	-	38	66	37	M8	15	10
	38-48				78									62				
	12-48				164									70				
42	1	265	450	560	14-45	126	50	26	20	3	95	-	46	75	40	M8	20	10
	42-55				94									65				
	14-55				176									75				
48	1	310	525	655	15-52	140	56	28	21	3,5	105	-	51	85	45	M8	20	10
	48-62				104									69				
	15-62				188									80				
55	1	410	685	825	20-60	160	65	30	22	4	120	-	60	98	52	M10	20	17
	55-74				118													
65	1	625	940	1175	22-70	185	75	35	26	4,5	135	-	68	115	61	M10	20	17
75	1	1280	1920	2400	30-80	210	85	40	30	5	160	-	80	135	69	M10	25	17
90	1	2400	3600	4500	40-97	245	100	45	34	5,5	200	218	100	160	81	M12	30	40

ROTEX® Nodular iron (GJS)

100	1	3300	4950	6185	50-115	270	110	50	38	6	225	246	113	180	89	M12	30	40
110	1	4800	7200	9000	60-125	295	120	55	42	6,5	255	276	127	200	96	M16	35	80
125	1	6650	10000	12500	60-145	340	140	60	46	7	290	315	147	230	112	M16	40	80
140	1	8550	12800	16000	60-160	375	155	65	50	7,5	320	345	165	255	124	M20	45	140
160	1	12800	19200	24000	80-185	425	175	75	57	9	370	400	190	290	140	M20	50	140
180	1	18650	28000	35000	85-200	475	195	85	64	10,5	420	450	220	325	156	M20	50	140

¹⁾ = If no material is mentioned in the order, the calculation/order is based on the material marked with

¹⁾ Maximum torque of the coupling T_{Kmax} = rated torque of the coupling T_{KNenn} · x 2. Selection see page 20/21

²⁾ Material Al-H.

Order form:

ROTEX® 38	GJL	92 Sh-A	1a	–	Ø 45	1	–	Ø 25
Coupling size	Material	Spider hardness	Component		Finish bore	Component		Finish bore

Shaft coupling design No. 001 - material steel



- Hubs from steel, specifically suitable for drive elements subject to high loads, e. g. steel mills, elevator drives, spline hubs, etc.)
- Torsionally flexible, maintenance-free, vibration-damping
- Axial plug-in, fail-safe
- All-over machining - good dynamic properties
- Compact design/small flywheel effect
- Finish bore according to ISO fit H7, feather keyway according to DIN 6885 sheet 1 - JS9
- Stock programme/basic programme see pages 28 and 29
- Approved according to EC Standard 94/9/EC
- Mounting instructions under www.ktr.com

Components

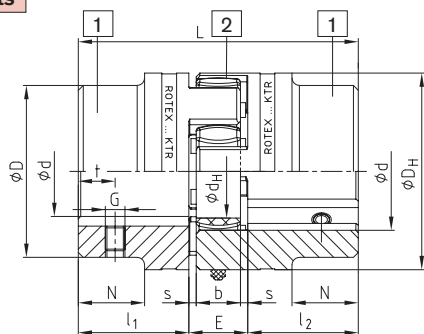

Steel (thread on the keyway)

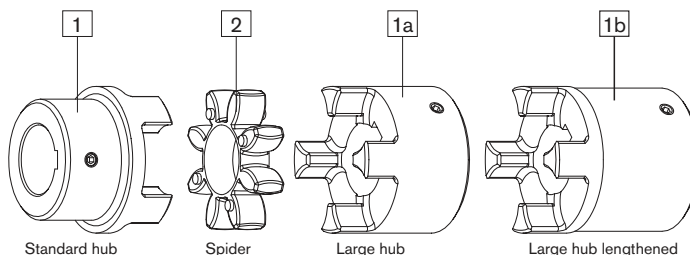

ROTEX® steel (St)																	
Size	Component	Spider (part 2) ¹⁾			Finish bore d (min-max)	Dimensions [mm]											
		Rated torque [Nm]				General										Thread for setscrews	
		92 Sh-A	98 Sh-A	64 Sh-D		L	l ₁ ; l ₂	E	b	s	D _H	d _H	D	N	G	t	T _A [Nm]
14	1a	7,5	12,5	16	0-16	35	11	13	10	1,5	30	10	30	-	M4	5	1,5
	1b					50	18,5										
19	1a	10	17	21	0-25	66	25	16	12	2	40	18	40	-	M5	10	2
	1b					90	37										
24	1a	35	60	75	0-35	78	30	18	14	2	55	27	55	-	M5	10	2
	1b					118	50										
28	1a	95	160	200	0-40	90	35	20	15	2,5	65	30	65	-	M8	15	10
	1b					140	60										
38	1	190	325	405	0-48	114	45	24	18	3	80	38	70	27	M8	15	10
	1b					164	70						80	-			
42	1	265	450	560	0-55	126	50	26	20	3	95	46	85	28	M8	20	10
	1b					176	75						95	-			
48	1	310	525	655	0-62	140	56	28	21	3,5	105	51	95	32	M8	20	10
	1b					188	80						105	-			
55	1	410	685	825	0-74	160	65	30	22	4	120	60	110	37	M10	20	17
	1b					210	90						120	-			
65	1	625	940	1175	0-80	185	75	35	26	4,5	135	68	115	47	M10	20	17
	1b					235	100						135	-			
75	1	1280	1920	2400	0-95	210	85	40	30	5	160	80	135	53	M10	25	17
	1b					260	110						160	-			
90	1	2400	3600	4500	0-110	245	100	45	34	5,5	200	100	160	62	M12	30	40
	1b					295	125						200	-			

ROTEX® sintered steel																	
Size	Component	Spider (part 2) ¹⁾		Finish bore d	Dimensions [mm]												
		Rated torque [Nm]			General										Thread for setscrews		
		92 Sh-A	98 Sh-A		L	l ₁ ; l ₂	E	b	s	D _H	d _H	D	N	G	t	T _A [Nm]	
14	1a	7,5	12,5	unbored, 8, 10, 11, 12, 14, 15, 16	35	11	13	10	1,5	30	10	30	-	M4	5	1,5	
19	1a	10	17	unbored, 14, 16, 19, 20, 22, 24	66	25	16	12	2	40	18	40	-	M5	10	2	

¹⁾ = If no material is mentioned in the order, the calculation/order is based on the material marked with ¹⁾ Maximum torque of the coupling T_{Kmax}. = rated torque of the coupling T_{K Nenn}. x 2. Selection see page 20/21

ROTEX® 19 – 48 from stainless steel available from stock

- ROTEX® 19, 28 and 42 – hub material X10CrNiS 18-9 material number 1.4305 (V2A) DIN 17440
- ROTEX® 24, 38 and 48 – hub material X6CrNiMoTi 17-12-2 material number 1.4571 (V4A) DIN 17440

Order form:	ROTEX® 38	St	92 Sh-A	1	-	Ø 45	1	-	Ø 25
	Coupling size	Material	Spider hardness	Component	Finish bore	Component	Finish bore		

Shaft coupling design No. 001 with Taper clamping bush



- Shaft coupling with taper clamping bush
- Sliding fit facilitates the axial alignment of the coupling
- Short mounting length
- Easy assembly/disassembly of the coupling hubs
- Extra securing by positive locking, the clamping screws are each mounted by half in the coupling hub and in the taper clamping bush

Components

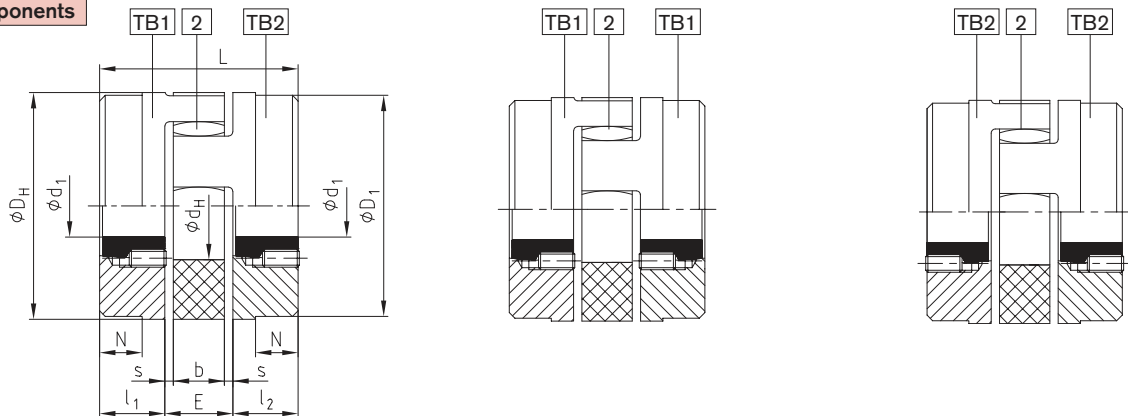

ROTEX® type No. 001 with taper clamping bush

Size	Taper clamping bush	Dimensions [mm]									Fixing screw for taper bush			
		$l_1:l_2$	E	s	b	L	N	D_H	D_1	d_H	Size [Inch]	Length [mm]	Number	T_A [Nm]
24	1008	23	18	2,0	14	64	–	55	55	27	1/4	13	2	5,7
28	1108	23	20	2,5	15	66	–	65	65	30	1/4"	13	2	5,7
38	1108	23	24	3,0	18	70	15	80	78	38	1/4"	13	2	5,7
42	1610	26	26	3,0	20	78	16	95	94	46	3/8"	16	2	20
48	1615	39	28	3,5	21	106	28	105	104	51	3/8"	16	2	20
55	2012	33	30	4,0	22	96	20	120	118	60	7/16"	22	2	31
65	2012	33	35	4,5	26	101	19	135	115	68	7/16"	22	2	31
75	2517	52	40	5,0	30	144	36	160	158	80	1/2"	25	2	49
	5/8"										32	2	92	
90	3020	52	45	5,5	34	149	33	200	160	100	5/8"	32	2	92
125	3535	90	60	7,0	46	288	86	230	290	147	1/2"	49	3	113
	3/4"										192			

● Only available for design TB 2
* 1. BSW thread

Coupling type TB 1/1; TB 2/2; TB 1/2 possible

● Please order our separate dimension sheet (M 373054).

Taper clamping bush

Size	Bore dimensions d_1 [mm] available; H7 fit – keyways to DIN 6885 sheet 1																		
1008	Ø10	Ø11	Ø12	Ø14	Ø16	Ø18	Ø19	Ø20	Ø22	Ø24	Ø25								
1108	Ø10	Ø11	Ø12	Ø14	Ø16	Ø18	Ø19	Ø20	Ø22	Ø24	Ø25	Ø28*							
1610	Ø14	Ø16	Ø18	Ø19	Ø20	Ø22	Ø24	Ø25	Ø28	Ø30	Ø32	Ø35	Ø38	Ø40	Ø42*				
1615	Ø14	Ø16	Ø18	Ø19	Ø20	Ø22	Ø24	Ø25	Ø28	Ø30	Ø32	Ø35	Ø38	Ø40	Ø42*				
2012	Ø14	Ø16	Ø18	Ø19	Ø20	Ø22	Ø24	Ø25	Ø28	Ø30	Ø32	Ø35	Ø38	Ø40	Ø42	Ø45	Ø48	Ø50	
2517	Ø16	Ø18	Ø19	Ø20	Ø22	Ø24	Ø25	Ø28	Ø30	Ø32	Ø35	Ø38	Ø40	Ø42	Ø45	Ø48	Ø50	Ø55	Ø60
3020	Ø25	Ø28	Ø30	Ø35	Ø38	Ø40	Ø42	Ø45	Ø48	Ø50	Ø55	Ø60	Ø65	Ø70	Ø75				
3535	Ø35	Ø38	Ø40	Ø42	Ø45	Ø48	Ø50	Ø55	Ø60	Ø65	Ø70	Ø75	Ø80	Ø85	Ø90				
4545	Ø55	Ø60	Ø65	Ø70	Ø75	Ø80	Ø85	Ø90	Ø95	Ø100	Ø105	Ø110							

* Bores with keyway (flat design) to DIN 6885 sheet 3

Order form:

ROTEX® 38	92 Sh-A	1108	TB1 – Ø 24	TB2 – Ø 22
Coupling size	Spider hardness	Taper clamping bush	Hub design	Finish bore
			Hub design	Finish bore

Clamping ring hubs

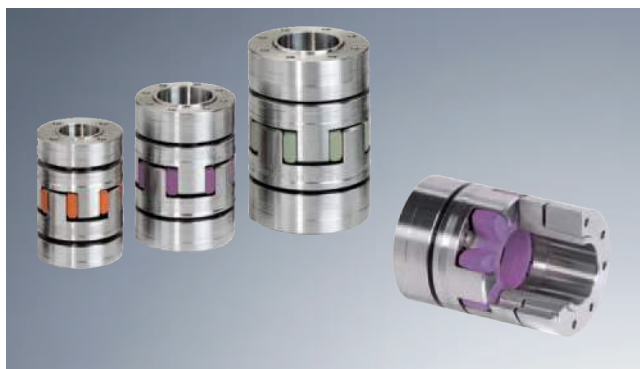

- Torsionally flexible shaft coupling with integrated clamping system
- High smoothness of running, application up to a peripheral speed of 40 m/s
- For high friction torques (consider the selection in case of explosion protection use)
- Easy to assemble due to internal clamping screws
- Finish bore up to Ø 50 mm according to ISO fit H7, from Ø 55 mm according to ISO fit G7
- Approved according to EC Standard 94/9/EC

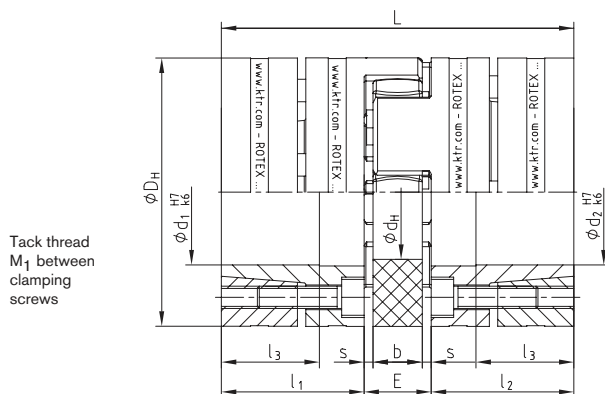

Size	Torques [Nm] ¹⁾				Dimensions [mm]									Clamping screws			Weight per hub with max. bore [kg]	Mass moment of inertia per hub with max. bore [kgm ²]	
	92 Sh A		98 Sh A		D _H ³⁾	d _H	L	l ₁ ; l ₂	l ₃	E	b	s	M	number z	T _A [Nm]	M ₁			
Hub and clamping ring material – Steel (St-H)																			
19	10,0	20	17	34	40	18	66	25	18	16	12	2,0	M4	6	4,1	M4	0,179	0,44 x 10 ⁻⁴	
24	35,0	70	60	120	55	27	78	30	22	18	14	2,0	M5	4	8,5	M5	0,399	1,91 x 10 ⁻⁴	
28	95,0	190	160	320	65	30	90	35	27	20	15	2,5	M5	8	8,5	M5	0,592	4,18 x 10 ⁻⁴	
38	190,0	380	325	650	80	38	114	45	35	24	18	3,0	M6	8	14	M6	1,225	12,9 x 10 ⁻⁴	
42	265	530	450	900	95	46	126	50	35	26	20	3,0	M8	4	35	M8	2,30	31,7 x 10 ⁻⁴	
48	310	620	525	1050	105	51	140	56	41	28	21	3,5	M10	4	69	M10	3,08	52,0 x 10 ⁻⁴	
55	375	750	685	1370	120	60	160	65	45	30	22	4,0	M10	4	69	M10	4,67	103,0 x 10 ⁻⁴	
65	-	-	940 ²⁾	1880 ²⁾	135	68	185	75	55	35	26	4,5	M12	4	120	M12	6,70	191,0 x 10 ⁻⁴	
75	-	-	1920 ²⁾	3840 ²⁾	160	80	210	85	63	40	30	5,0	M12	5	120	M12	9,90	396,8 x 10 ⁻⁴	
NEW 90	-	-	3600 ²⁾	4500 ²⁾	200	104	245	100	75	45	34	5,5	M16	5	295	M16	17,70	1136 x 10 ⁻⁴	

¹⁾ Please note coupling selection on pages 140/141 ²⁾ Figures for 95 Sh A - GS ³⁾ ØD_H + 2 mm with high speeds for expansion of spider

Size	Bore d ₁ /d ₂ and the corresponding transmittable friction torques T _R of clamping ring hub in [Nm] ¹⁾																											
	Ø10	Ø11	Ø14	Ø15	Ø16	Ø19	Ø20	Ø24	Ø28	Ø30	Ø32	Ø35	Ø38	Ø40	Ø42	Ø45	Ø48	Ø50	Ø55	Ø60	Ø65	Ø70	Ø80	Ø90	Ø95	Ø100	Ø105	
19	27	32	69	84	57	94	110																					
24			70	87	56	97	114	116	133	192																		
28				108	131	207	148	253	285	315	382	330	433	503														
38							208	353	395	439	531	463	603	593	689	793	776											
42									358	398	483	416	547	536	625	571	704	851	865									
48											616	704	899	896	1030	962	1160	1379	1222	1543								
55												863	856	991	918	1119	1110	1247	1277	1672	1605	2008						
65														1446	1355	1637	1635	1827	1887	2429	2368	2930						
75															1710	2053	2059	2294	2384	3040	2983	3664	4293					
NEW 90																		3845	4249	4794	5858	5900	7036	8047	9247	9575	10845	

The transmittable torques of the clamping connection consider the max. clearance with shaft fit k6 / bore H7, from Ø55 G7/m6. With bigger clearance the torque is reduced. For the stiffness calculation of the shaft/hollow shaft see KTR standard 45510 at our homepage www.ktr.com

Order form:	ROTEX® GS 24	98 Sh-A	6.0 - Steel – Ø 24	6.0 - Steel – Ø 20
	Coupling size	Spider hardness	Hub design	Finish bore

Clamping hubs



- Standard hub material steel
- Suitable in combination with spline hubs according to DIN 5480, DIN 5482, SAE J498 (see page 28) and in addition DIN 9611, DIN 5463 (ISO 14), DIN 5481 and DIN 5472
- Balanced on the basis of 3D-CAD data
- Axial plug-in, fail-safe
- Particularly suitable for applications with reversing operation
- Protection assessed and confirmed in accordance with EU standard 94/9/EC (only for hub designs 2.1 and 2.3, hub design 2.0 only according to category 3)
- Mounting instructions under www.ktr.com

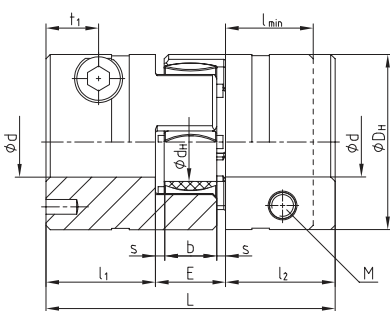

ROTEX® 19 - 28

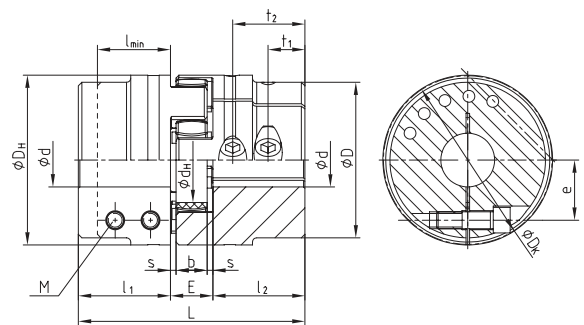

ROTEX® 38 - 90

ROTEX® with clamping hubs																		
Size	Dimensions [mm]																Screw DIN EN ISO 4762	
	max. d	L	$l_{1,2}$	l_{min}	E	b	s	D_H	D	d_H	D_K	t_1	t_2	e	M	T_A [Nm]		
19	20 ¹⁾	66	25	20	16	12	2	40	-	18	46,0	12	-	14,5	M6	14		
24	28	78	30	25	18	14	2	55	-	27	57,5	12	-	20,0	M6	14		
28	38	90	35	30	20	15	2,5	65	-	30	73,0	14 ²⁾	-	25,0	M8	35		
38	42	114	45	35	24	18	3	80	70	38	77,5	19	-	26,5	M8	35		
42	50	126	50	42	26	20	3	95	85	46	93,5	18 ²⁾	-	32,0	M10	69		
48	55	140	56	46	28	21	3,5	105	95	51	105,0	21 ²⁾	-	36,0	M12	120		
55	68	160	65	50	30	22	4	120	110	60	119,5	26	51 ²⁾	42,5 ³⁾	M12	120		
65	70	185	75	55	35	26	4,5	135	115	68	132,5	33	61 ²⁾	50,0 ³⁾	M12	120		
75	80	210	85	65	40	30	5	160	135	80	158,0	36	68 ²⁾	57,0 ³⁾	M16	295		
90	90	245	100	80	45	34	5,5	200	160	100	197,0	40	80 ²⁾	72,0 ³⁾	M20	580		

Bore area and the corresponding transmittable friction torques [Nm] of ROTEX® clamping design 2.0																															
Size	Ø8	Ø10	Ø11	Ø14	Ø15	Ø16	Ø18	Ø19	Ø20	Ø22	Ø24	Ø25	Ø28	Ø30	Ø32	Ø35	Ø38	Ø40	Ø42	Ø45	Ø48	Ø50	Ø55	Ø60	Ø65	Ø70	Ø75	Ø80	Ø85	Ø90	
19	44	46	47	51	52	53	55	57	58																						
24		59	60	64	65	66	68	70	71	73	76	77	80																		
28				139	141	144	148	150	152	157	161	163	170	174	178	185	191														
38					163	165	170	172	174	178	183	185	192	196	200	207	213	217	222												
42									291	297	304	308	318	325	332	342	353	360	367	377	387	394									
48									466	476	486	491	506	516	526	542	557	567	577	592	607	618	643								
55															1185	1215	1245	1266	1286	1316	1347	1367	1417	1468	1519						
65																1316	1347	1367	1387	1417	1448	1468	1519	1569	1620	1671					
75																			2869	2926	2983	3022	3117	3213	3309	3404	3500	3595			
90																				5220	5310	5400	5460	5610	5760	5910	6060	6210	6360	6510	6660

¹⁾ With design 2.1 d_{max} Ø17 mm

²⁾ With reduced hubs the dimension t_1 varies or the number of screws changes from 2-off to 1-off

³⁾ t_1 and t_2 have a different e dimension

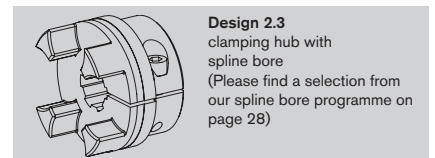
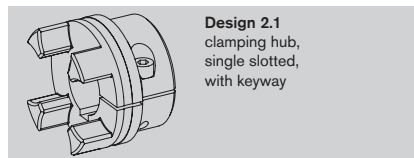
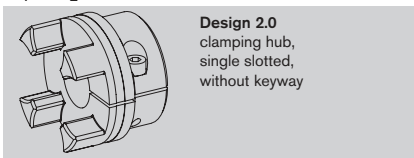

Order form:	ROTEX® 24	98 Sh-A	2.1	-	Ø 24	2.0	-	Ø 20
	Coupling size	Spider hardness	Hub design	Finish bore	Hub design	Finish bore		

Flange programme types AFN and BFN



- Double flange design AFN and flange design BFN applicable to heavy machinery
- Radial assembly of driving or driven machine after disassembly of driving flanges
- For design AFN - spider interchangeable while coupling installed, without removal of driving or driven machine
- Power flow can be disconnected while coupling is installed
- Flange materials: comp. 4 N steel
comp. 3 Na GJS
- Finish bore according to ISO fit H7,
feather keyway according to DIN 6885 sheet 1 - JS9
- Approved according to EC Standard 94/9/EC

Components

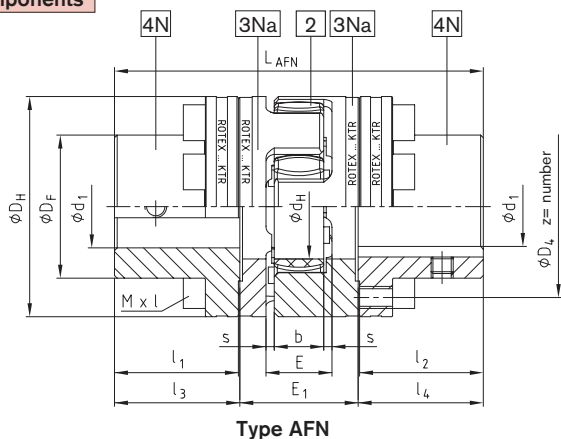

Type AFN

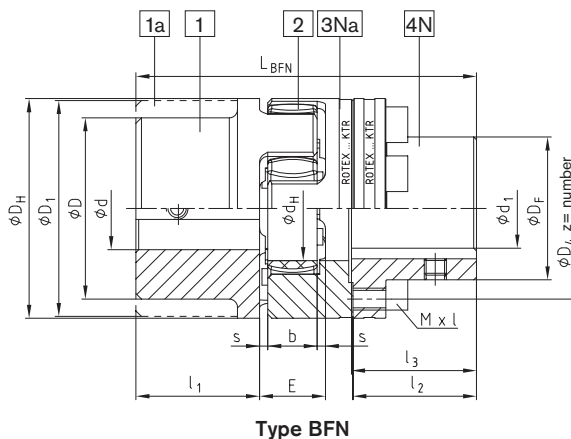

Type BFN

ROTEX® AFN (No. 002) and BFN (No. 004)

Size	Pilot bored Ød; ØD; ØD ₁	Component 4N max. finish bore Ød ₁	Dimensions [mm]											Cyl. screws ³⁾ DIN EN ISO 4762 - 12.9				
			D _H	D _F	D ₄	d _H	l ₁ ; l ₂	E	E ₁	s	b	l ₃ ; l ₄	L _{AFN}	L _{BFN}	M x l	z	Pitch ²⁾	¹⁾ T _A [Nm]
24		24	55	36	45	27	30	18	33	2,0	14	30,5	94	86	M5x16	8		10
28	see shaft coupling on pages 30 and 31 stock programme/basic programme see pages 28 and 29	28	65	42	54	30	35	20	39	2,5	15	35,5	110	100	M6x20	8	8x45°	17
38		38	80	52	66	38	45	24	43	3,0	18	45,5	134	124	M8x22	8		41
42		42	95	62	80	46	50	26	48	3,0	20	51,0	150	138	M8x25	12	16x22,5°	41
48		48	105	70	90	51	56	28	50	3,5	21	57,0	164	152	M8x25	12		41
55		55	120	80	102	60	65	30	60	4,0	22	66,0	192	176	M10x30	8	8x45°	83
65		65	135	94	116	68	75	35	65	4,5	26	76,0	217	201	M10x30	12	16x22,5°	83
75		75	160	108	136	80	85	40	75	5,0	30	86,5	248	229	M12x40	15		120
90		100	200	142	172	100	100	45	82	5,5	34	101,5	285	265	M16x40	15		295
100		110	225	158	195	113	110	50	97	6,0	38	111,5	320	295	M16x50	15		295
110		125	255	178	218	127	120	55	103	6,5	42	122,0	347	321	M20x50	15	20x18°	580
125	145	290	206	252	147	140	60	116	7,0	46	142,0	400	370	M20x60	15		580	
140	165	320	235	282	165	155	65	128	7,5	50	157,5	443	409	M20x60	15		580	
160	190	370	270	325	190	175	75	146	9,0	57	177,5	501	463	M24x70	15		1000	
180	220	420	315	375	220	195	85	159	10,5	64	198,0	555	515	M24x80	18	24x15°	1000	

¹⁾ Screw tightening torque T_A [Nm].

²⁾ Thread in driving flange between cams.

³⁾ Coupling is delivered not assembled.

Order form

ROTEX® 38	AFN	92 Sh-A	4N	-	Ø 38	4N	-	Ø 35
Coupling size	Type	Spider hardness	Component	Finish bore	Component	Finish bore		

Drop-out center design coupling type A-H



- Assembly/disassembly by means of 4 screws only
- Exchange of spider with no need to shift the driving and driven side (motor and pump)
- Positive-locking and frictionally engaged hub combinations to be assembled radially (dimension E₁ of design AFN = dimension E₁ of A-H)
- Finish bore according to ISO tolerance H7, feather key according to DIN 6885 sheet 1 - JS9
- Please order our separate dimension sheet (M425460)
-  Approved according to EC Standard 94/9/EC (type 7.8 shell clamping hub without feather key according to category 3)

Components

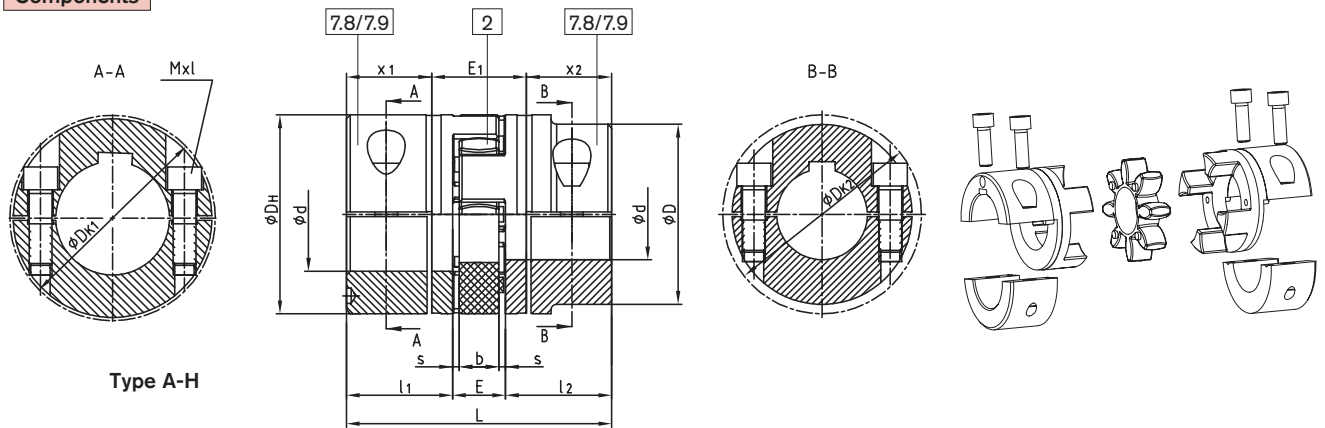

Type A-H

ROTEX® Type A-H															
Size	max. Finish bore Ød [mm]	Dimension [mm]											Cyl. screw DIN EN ISO 4762		
		L	l ₁ :l ₂	E	b	s	D _H	D	D _{K1}	D _{K2}	x ₁ /x ₂	E ₁	Mxl	Tightening torque T _A [Nm]	
19	20	66	25	16	12	2,0	40	-	46	-	17,5	31	M6x16	14	
24	28	78	30	18	14	2,0	55	-	57,5	-	22,5	33	M6x20	14	
28	38	90	35	20	15	2,5	65	-	73	-	25,5	39	M8x25	35	
38	45	114	45	24	18	3,0	80	-	83,5	-	35,5	43	M8x30	35	
42	50	126	50	26	20	3,0	95	85	-	93,5	39	48	M10x30	69	
	55							-	97	M10x35					
48	55	140	56	28	21	3,5	105	95	-	105	45	50	M12x35	120	
	60							108,5	-	M12x40					
55	65	160	65	30	22	4,0	120	110	-	119,5	50	60	M12x40	120	
	70							122	-	M12x45					
65	70	185	75	35	26	4,5	135	115	-	123,5	60	65	M12x40	120	
	80							132,5	-	M12x45					
75	80	210	85	40	30	5,0	160	135	-	147,5	67,5	75	M16x50	295	
	90							158	-	M16x50					
90	90	245	100	45	34	5,5	200	160	-	176	81,5	82	M20x60	580	
	110							197	-	M20x60					
100 ¹⁾	110	270	110	50	38	6,0	225	180	-	185,5	84	102	M16x50	295	
110 ¹⁾	120	295	120	55	42	6,5	255	200	-	208	90	115	M20x60	580	
125 ¹⁾	140	340	140	60	46	7,0	290	230	-	242,5	105	130	M24x70	1000	

Please note:

With maximum bore the feather keys are offset to each other by approx. 5°

Hub materials: up to size 90 Steel
from size 100 GJS

7.8 = Shell clamping hub without feather key

7.9 = Shell clamping hub with feather key

¹⁾ From size 100: 4 clamping screws for each clamping hub.

Order form	ROTEX® 38	A-H	98 Sh-A	7.8	-	Ø 38	7.8	-	Ø 30
	Coupling size	Type	Spider hardness	Component	Finish bore	Component	Finish bore		

Flange programme types CF, CFN, DF and DFN

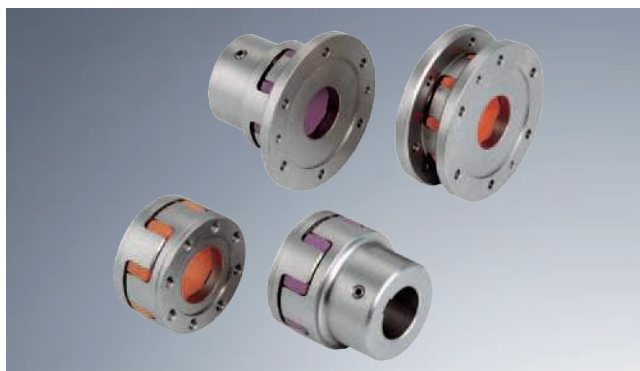

- Flange designs applicable to heavy machinery
- CF and CFN - connection flange to shaft
- DF and DFN - double flange design for the connection of driving and driven machine, radial assembly possible without removal of other components p quick replacement of spider
- CFN and DFN - particularly small outside diameters
- DF and DFN – compact design
- DFN - for customer-specific mounting flanges
- Flange material part 3b: GJS
- Finish bore according to ISO fit H7, feather keyway according to DIN 6885 sheet 1 - JS9
- Approved according to EC Standard 94/9/EC

Components

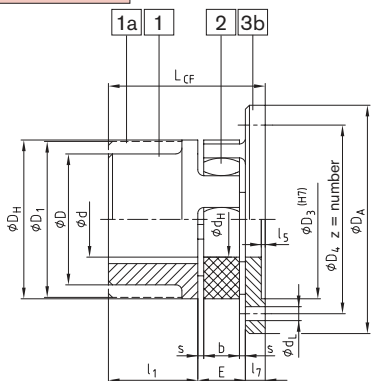

Type CF

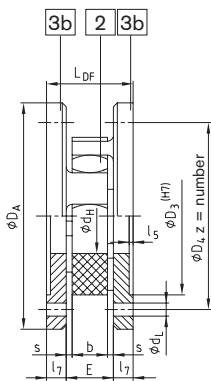

Type DF

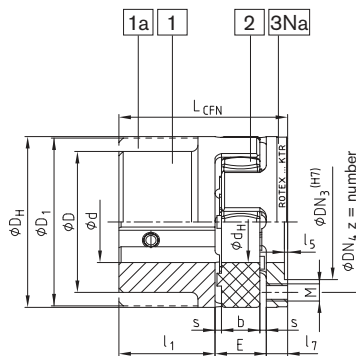

Type CFN

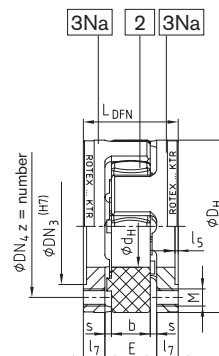

Type DFN

ROTEX® CF, CFN (No. 005) and DF, DFN (No. 006)																							
Size	ød øD øD ₁	General dimension								Dimensions CF and DF						Dimensions CFN and DFN							
		D _H	d _H	l ₁	E	s	b	l ₅	l ₇	D _A	D ₃	D ₄	z	d _L	L _{CF}	L _{DF}	DN ₃	DN ₄	M	z	Pitch ²⁾	L _{CFN}	L _{DFN}
24		55	27	30	18	2,0	14	1,5	8	80	55	65	5	4,5	56	34	36	45	M5	8		56	34
28		65	30	35	20	2,5	15	1,5	10	100	65	80	6	6,6	65	40	44	54	M6	8	8x45°	65	40
38		80	38	45	24	3,0	18	1,5	10	115	80	95	6	6,6	79	44	54	66	M8	8		79	44
42	see shaft coupling on pages 30 and 31 stock programme/basic programme see pages 28 and 29	95	46	50	26	3,0	20	2,0	12	140	95	115	6	9,0	88	50	65	80	M8	12	16x22,5°	88	50
48		105	51	56	28	3,5	21	2,0	12	150	105	125	8	9,0	96	52	75	90	M8	12		96	52
55		120	60	65	30	4,0	22	2,0	16	175	120	145	8	11,0	111	62	84	102	M10	8	8x45°	111	62
65		135	68	75	35	4,5	26	2,0	16	190	135	160	10	11,0	126	67	96	116	M10	12	16x22,5°	126	67
75		160	80	85	40	5,0	30	2,5	19	215	160	185	10	13,5	144	78	112	136	M12	15		144	78
90		200	100	100	45	5,5	34	3,0	20	260	200	225	12	13,5	165	85	145	172	M16	15		165	85
100		225	113	110	50	6,0	38	4,0	25	285	225	250	12	13,5	185	100	165	195	M16	15		185	100
110		255	127	120	55	6,5	42	4,0	26	330	255	290	12	18,0	201	107	180	218	M20	15	20x18°	201	107
125		290	147	140	60	7,0	46	5,0	30	370	290	325	16	18,0	230	120	215	252	M20	15		230	120
140		320	165	155	65	7,5	50	5,0	34	410	320	360	16	22,0	254	133	245	282	M20	15		254	133
160	370	190	175	75	9,0	57	5,0	38	460	370	410	16	22,0	288	151	280	325	M24	15		288	151	
180	420	220	195	85	10,5	64	5,5	40	520	420	465	16	26,0	320	165	330	375	M24	18	24x15°	320	165	

Other flange dimensions see page 35

Further types: ROTEX® CF-H
Flange drop-put center design coupling

Please order our separate dimension sheet (M412069)

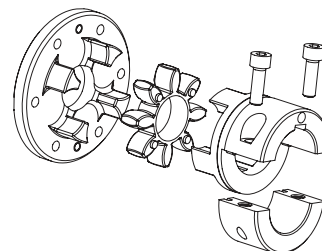

Order form:	ROTEX® 38	CF	92 Sh-A	1	-	GJL	-	ø 20
	Coupling size	Type	Spider hardness	Hub part Component		Material		Finish bore

Double cardanic type ZS-DKM-H

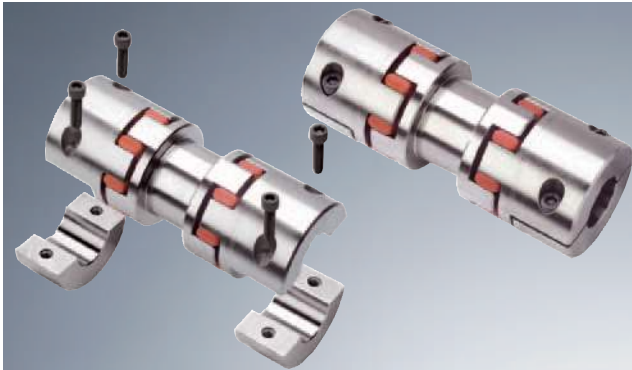

- Standard spacers up to 250 mm shaft distance dimension – ex stock
- Assembly/disassembly through 4 screws only
- Compensates for high shaft displacements due to double-cardanic design
- Remains torsionally symmetric in case of shaft displacements
- Reduced vibration and noise
- Low restoring forces \Rightarrow Increase of the total lifetime of all adjacent components (bearings, seals etc.)
- Approved according to EC Standard 94/9/EC (Explosion Certificate ATEX 95) (type 7.6 marked at stock, type 7.5 shell clamping hub without feather key according to category 3)

Components

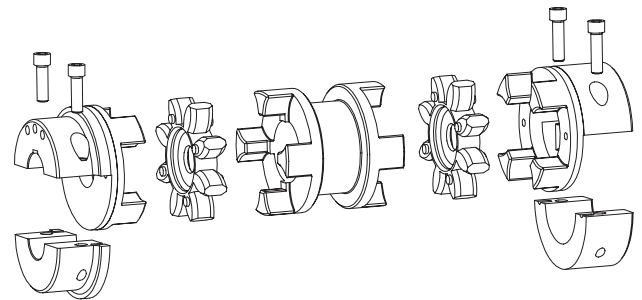
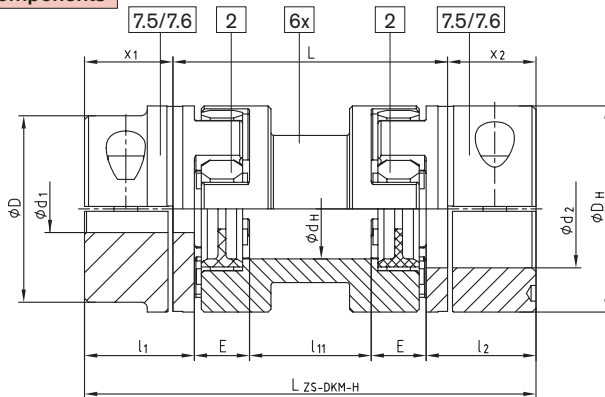

Type ZS-DKM-H

ROTEX® ZS-DKM-H																		
Size	Dismountable length L [mm]	Max. finish bore $\phi d_1/d_2$ [mm]	Spider (part 2) ¹⁾ T_{KN} [Nm]	Dimensions [mm]							Cap screw DIN EN ISO 4762 - 12.9		Max. displacements				Weight ²⁾ [kg]	
				d_H	d_H	$l_1; l_2$	$x_1; x_2$	l_{11}	E	L _{ZS-DKM-H}	M	T_A [Nm]	Axial [mm]	at n = 1500 rpm		at n = 3000 rpm		
													Radial [mm]	Angular [°]	Radial [mm]	Angular [°]		
24	100	28	35	55	27	30	22,5	49	18	145	M6	14	1,4	1,17	0,87	1,40	0,75	1,40
	89							185		1,87				1,90				
28	100	38	95	65	30	35	25,5	41	20	151	M8	35	1,5	1,06	0,80	1,32	0,75	1,90
	81							191		1,76				2,20				
38	100	45	190	80	38	45	35,5	33	24	171	M8	35	1,8	0,99	0,74	1,27	0,75	3,90
	73							211		1,69				4,10				
42	100	55	265	95	46	50	39,0	26	26	178	M10	69	2,0	0,91	0,68	1,20	0,75	5,10
	66							218		1,60				5,70				
48	100	60	310	105	51	56	45,0	22	28	190	M12	120	2,1	0,87	0,65	1,18	0,75	7,10
	62							230		1,57				7,90				
55	100	70	410	120	60	65	50,0	10	30	200	M12	120	2,2	0,70	0,52	1,05	0,75	9,50
	50							240		1,40				11,20				
65	140	80	625	135	68	75	60,0	90	35	280	M12	120	2,6	2,09	1,57	1,83	0,75	12,30
	110							300		2,44				12,80				
75	140	90	1280	160	80	85	67,5	40	40	260	M12	120	3,0	1,31	0,98	1,50	0,75	16,10
	25							300		2,00				16,80				
90	180	110	2400	200	100	100	81,5	25	45	275	M16	295	3,4	1,13	0,85	1,37	0,75	23,60
	65							315		1,83				26,00				
90	200	110	2400	200	100	100	81,5	85	45	335	M16	295	3,0	2,19	1,64	2,29	0,75	27,00
	135							385		3,05				29,50				
90	180	110	2400	200	100	100	81,5	53	45	343	M20	580	3,4	1,71	1,28	1,28	0,75	48,90
	123							413		2,93				52,60				

¹⁾ Maximum torque of coupling T_{Kmax} . = nominal torque of coupling T_{KN} x 2
Size 24 to 90 spider type 95/98 Sh-A-GS
ZS-DKM-H: transmittable torque according to 92 Sh-A-GS

²⁾ Refer to max. bore

Finish bore according to ISO fit H7, feather keyway according to DIN 6885 sheet 1 - JS9

7.5= Shell clamping hub without feather key for a double-cardanic connection

7.6= Shell clamping hub with feather key for a double-cardanic connection

ATTENTION: The standard line is only for the horizontal assembly. Vertical assembly on request.

Order form	ROTEX® 38	ZS-DKM-H	140	98 Sh-A-GS	7.5	Ø38	7.5	Ø30
Coupling size		Type	Shaft distance dimension L	Spider hardness	Hub design	Finish bore	Hub design	Finish bore

Double cardanic type DKM



- For high shaft displacements, 3-part double-cardanic
- Reduced vibration and noise
- The restoring forces resulting from displacements are very low
- Increase of the total lifetime of all adjacent components (bearings, seals etc.)
- Approved according to EC Standard 94/9/EC (Explosion Certificate ATEX 95)
- Mounting instructions under www.ktr.com
- Double-cardanic design without the need for bearing support or external guarding

Components

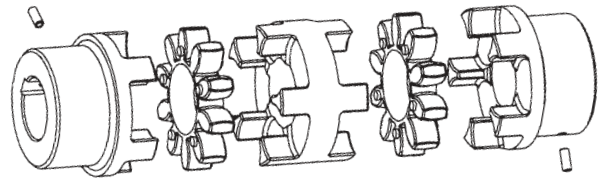
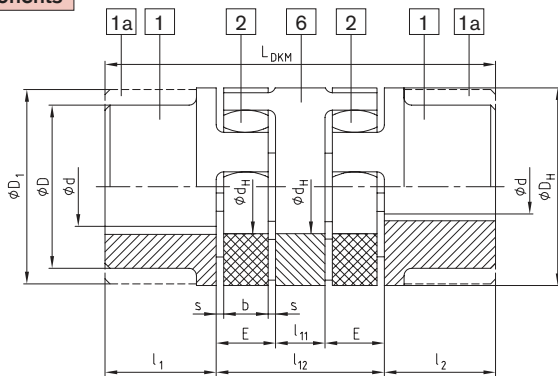

Type DKM

ROTEX® DKM (No. 018)															
Size	ϕd ϕD ϕD_1	Spider (part 2) Nominal torque [Nm] ¹⁾		Dimensions [mm]									Max. displacements at n = 1500 rpm		
		92 Sh-A	98 Sh-A	D_H	d_H	$l_1; l_2$	l_{11}	l_{12}	E	s	b	L_{DKM}	Radial [mm]	Angular [°]	Axial [mm]
19	see shaft coupling page 30 and 31; stock programme/basic programme page 28 and 29	10	17	40	18	25	10	42	16	2,0	12	92	0,45	1,0	+1,2/-1,0
24		35	60	55	27	30	16	52	18	2,0	14	112	0,59	1,0	+1,4/-1,0
28		95	160	65	30	35	18	58	20	2,5	15	128	0,66	1,0	+1,5/-1,4
38		190	325	80	38	45	20	68	24	3,0	18	158	0,77	1,0	+1,8/-1,4
42		265	450	95	46	50	22	74	26	3,0	20	174	0,84	1,0	+2,0/-2,0
48		310	525	105	51	56	24	80	28	3,5	21	192	0,91	1,0	+2,1/-2,0
55		410	685	120	60	65	28	88	30	4,0	22	218	1,01	1,0	+2,2/-2,0
65		625	940	135	68	75	32	102	35	4,5	26	252	1,17	1,0	+2,6/-2,0
75		1280	1920	160	80	85	36	116	40	5,0	30	286	1,33	1,0	+3,0/-3,0
90		2400	3600	200	100	100	40	130	45	5,5	34	330	1,48	1,0	+3,4/-3,0

¹⁾ Selection page 20/21

Finish bore according to ISO fit H7, feather keyway according to DIN 6885 sheet 1 - JS9

Order form:	ROTEX® 38	DKM	GJL	98 Sh-A	1 - Ø38	1 - Ø30	
	Coupling size	Type	Material	Spider hardness	Component	Finish bore	Component

Intermediate shaft programme type ZR

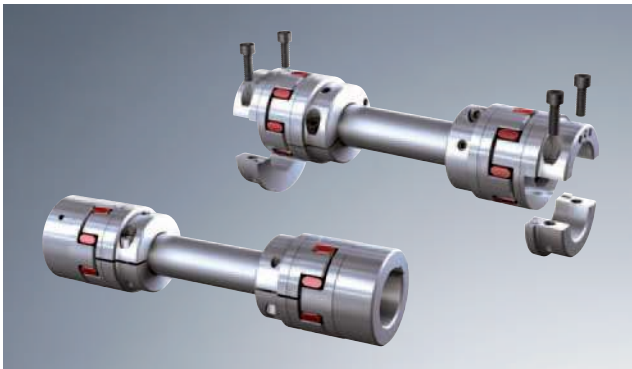

- To connect shaft ends with extended shaft separations
- Compensating for high shaft displacements due to the double-cardanic design
- Radial assembly possible without displacement of the driving or driven machine
- Particularly easy maintenance when using the semi-shell clamping hubs (type 7.5 and 7.6)
- Flexible bearing in backlash-free ROTEX® GS spiders

Components

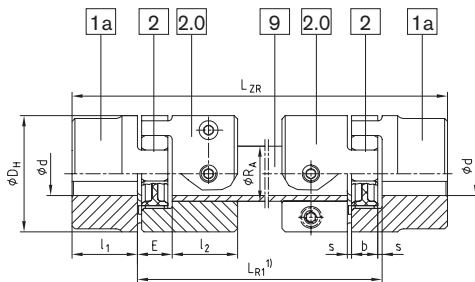

Type ZR
(with GS spider)

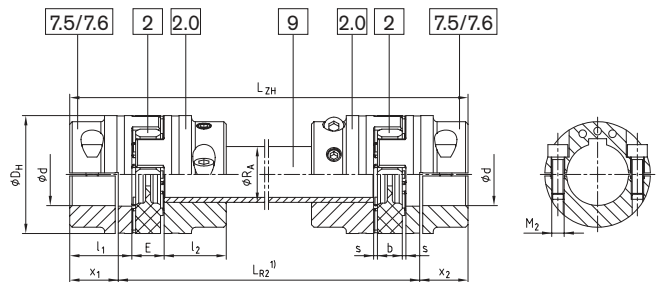
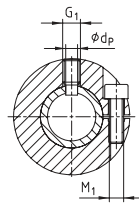

Type ZR
(with GS spider and shell clamping hub for a double-cardanic connection design 7.5 and 7.6)

ROTEX® type ZR (No. 037)

Size	Max. finish bore ϕd		Dimensions [mm]							Intermediate pipe Torsional stiffness/m R_A	Clamping screw Component 2.0 M_1	Clamping screw Component 1H T_A [Nm]	Clamping screw Component 1H M_2	Clamping screw Component 1H T_A [Nm]	L_{ZR}^1 L_{ZH}^1	min. LR_1	min. LR_2	Locking screw G_1	Locking pin d_p [mm]	Axial displacement [mm]	Angular displacement [degrees]
	Component 1a	Component 1H	D_H	$l_1; l_2$	$x_1; x_2$	E	s	b	C^2 [Nm ² /rad]												
19	25	20	40	25	17,5	16	2,0	12	$\phi 20 \times 3$	954,9	M6	14	M6	10		110	97	M6	4,0	1,2	0,9
24	35	28	55	30	22,5	18	2,0	14	$\phi 30 \times 4$	4522	M6	14	M6	14		128	111	M8	5,5	1,4	0,9
28	40	38	65	35	25,5	20	2,5	15	$\phi 35 \times 4$	7611	M8	35	M8	35		145	129	M10	7,0	1,5	0,9
38	48	45	80	45	35,5	24	3,0	18	$\phi 40 \times 4$	11870	M8	35	M8	25		180	157	M12	8,5	1,8	1,0
42	55	55	95	50	39,0	26	3,0	20	$\phi 45 \times 4$	17487	M10	69	M10	49		198	174	M12	8,5	2,0	1,0
48	62	60	105	56	45,0	28	3,5	21	$\phi 50 \times 4$	24648	M12	120	M12	86		217	190	M16	12	2,1	1,1
55	74	70	120	65	50,0	30	4,0	22	$\phi 55 \times 4$	39662	M12	120	M12	120		242	220	M16	12	2,2	1,1
65	80	80	135	75	60,0	35	4,5	26	$\phi 65 \times 5$	68329	M12	120	M12	120		281	250	M16	12	2,6	1,2
75	95	90	160	85	67,5	40	4,0	30	$\phi 75 \times 5$	108000	M16	295	M16	295		318	285	M16	12	3,0	1,2

¹⁾ Please indicate the shaft distance dimension L_1 in all inquiries and orders along with the maximum speed to review the critical whirling speed.

²⁾ Torsion spring stiffness when the intermediate pipe is 1m
Finish bore according to ISO fit H7, feather keyway according to DIN 6885 sheet 1 - JS9

Friction torques of clamping hubs have to be observed.

Please order dimension sheet no. 5020/000/017-757537.



Diagramme for coupling selection:

Order form:	ROTEX® 38	ZR	1200	St / GJL	98 Sh-A-GS	7.5 - $\phi 38$	7.5 - $\phi 30$
Coupling size	Type	Shaft distance dim. L_1/L_2	Material	Spider hardness	Component	Finish bore	Component

Type BTAN with brake drum/type SBAN with disk brake

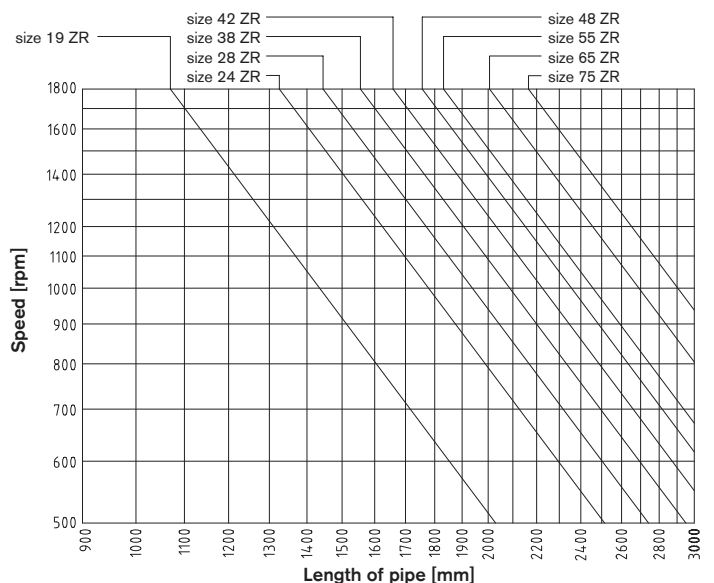

- Shaft coupling BTAN with brake drum to be mounted to external drum brakes with double shoes according to DIN 5431/15435
- Shaft coupling BTAN with disk for braking calipers
- Each coupling type to be combined with various sizes of brake drum disks (see dimension „N/C“)
- The brake drum or disk brake has to be placed onto the shaft end with the biggest mass moment of inertia
- The maximum brake torque must not exceed the maximum torque of the coupling
- Designs BTAN and SBAN - modification for customer from the stock programme
- Mounting instructions under www.ktr.com

Components

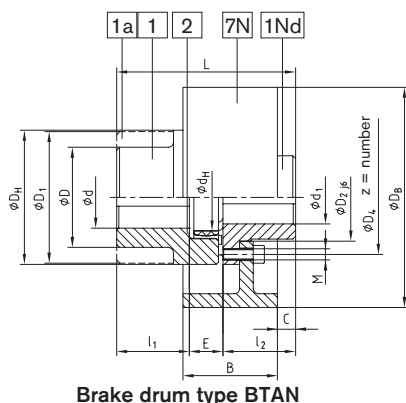

Brake drum type BTAN

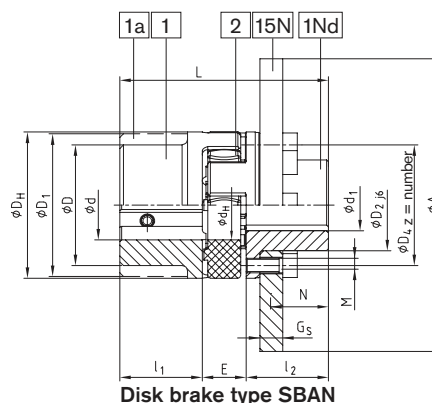

Disk brake type SBAN

ROTEX® type BTAN (No. 011) and SBAN (No. 013)

Size	Pilot bore ϕd ; ϕD ϕD_1	Finish bore max. d_1		Dimensions [mm]										
		GJS	Steel	D_H	D_2	D_4	d_H	z	pitch ¹⁾	M	T_A [Nm]	l_1 ; l_2	E	L
38	—	—	34	80	50	66	38	8	8 x 45°	M8	41	45	24	114
42	—	—	42	95	60	80	46	12	16 x 22,5°	M8	41	50	26	126
48	—	—	48	105	68	90	51	12		M8	41	56	28	140
55	—	—	55	120	78	102	60	8	8 x 45°	M10	83	65	30	160
65	—	—	65	135	92	116	68	12	16 x 22,5°	M10	83	75	35	185
75	—	—	75	160	106	136	80	15	20 x 18°	M12	120	85	40	210
90	—	—	100	200	140	172	100	15		M16	295	100	45	245
100	100	—	—	225	156	195	113	15	20 x 18°	M16	295	110	50	270
110	110	—	—	255	176	218	127	15		M20	580	120	55	295
125	130	—	—	290	204	252	147	15	M20	580	140	60	340	

¹⁾ Thread in the hub between the cams

Brake drum	Type BTAN										Speed rpm [V] (30 m/s)	Disk brake	Type SBAN										Speed rpm [V] (30 m/s)
	ROTEX® BTAN dimension „C“												ROTEX® SBAN dimension „N“										
	38	42	48	55	65	75	90	100	110	125		38	42	48	55	65	75	90	100	110	125		
160x60	14										3550	200x12,5	31,25										2800
200x75	9	12	17	24							2800	250x12,5	31,25	34,25	39,25								2240
250x95	1	4	9	16	25	33					2240	315x16		32,5	37,5	44,5	53,5	61,5					1800
315x118		-5	0	7	16	24	36				1800	400x16			37,5	44,5	53,5	61,5	73,5	81,5	88,5		1400
400x150		-18	-13	-6	3	11	23	31	38		1400	500x16				44,5	53,5	61,5	73,5	81,5	88,5	104,5	1120
500x190					-12	-4	8	16	23	39	1120	630x20					51,5	59,5	71,5	79,5	86,5	102,5	900
630x236						-22	-10	-2	5	21	900	710x20					51,5	59,5	71,5	79,5	86,5	102,5	800
710x265								-13	-6	10	800	800x25							69	77	84	100	710
800x300										-4	710	900x25									84	100	630

Other sizes on request according to dimension sheet no.:
 BTAN: M 380821
 SBAN straight: M380822; cranked: M 370065
 FNN hub: M 380823

Finish bore according to ISO fit H7, feather keyway according to DIN 6885 sheet 1 - JS9

Order form:	ROTEX® 38	BTAN	Ø200x75	92 Sh A	1Nd	—	Ø 38	1	—	Ø 30
	Coupling size	Type	Ø Brake drum x width of brake drum	Spider hardness	Component	Finish bore	Component	Finish bore		

Type AFN-SB special with disk brake

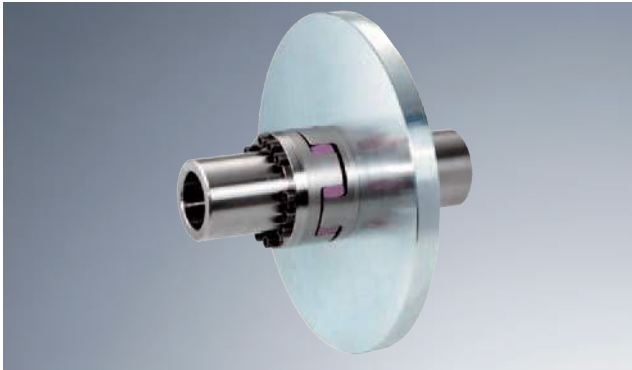

- Shaft coupling AFN-SB special with disk brake for braking calipers
- Brake disk and spider can be replaced while being assembled
- The disk brake has to be placed onto the shaft end with the biggest mass moment of inertia
- The maximum braking torque must not exceed the maximum torque of the coupling
- Finish bore according to ISO fit H7, feather keyway according to DIN 6885 sheet 1 - JS9
- Mounting instructions under www.ktr.com

Components

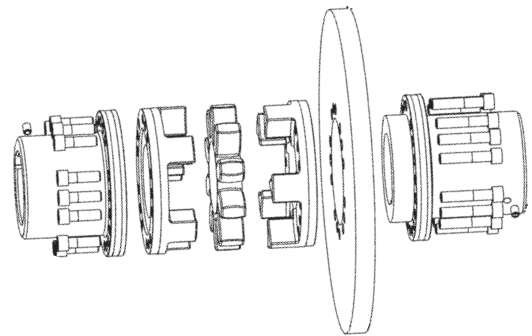
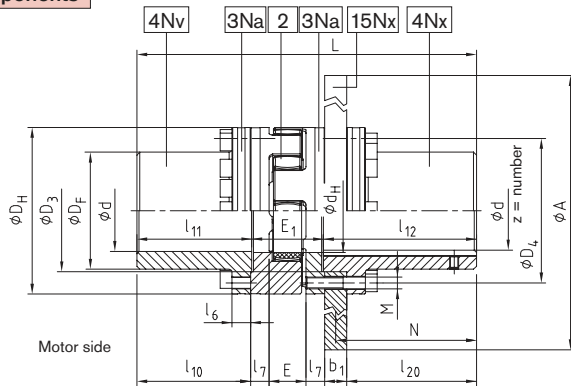

ROTEX® Type AFN-SB special													
Size	Finish bore d		Dimensions [mm]										
	min.	max.	D _H	D _F	D ₃ ^{H7/h7}	D ₄	d _H	E	E ₁	M	z	Pitch	T _A [Nm]
65	22	65	135	94	96	116	68	35	65	M10	12	16x22,5°	83
75	30	75	160	108	112	136	80	40	75	M12	15		120
90	40	100	200	142	145	172	100	45	82	M16	15		295
100	46	110	225	158	165	195	113	50	97	M16	15		295
110	60	125	255	178	180	218	127	55	103	M20	15	20x18°	580
125	60	145	290	206	215	252	147	60	116	M20	15		580
140	60	165	320	235	245	282	165	65	128	M20	15		580
160	80	190	370	270	280	325	190	75	146	M24	15		1000

ROTEX® Type AFN-SB special											
Size	Torque ¹⁾ mit 95Sh-A		Max. speed [rpm]	Max.brake torque [Nm] ²⁾	Dimensions [mm]						
	T _{KN}	T _{Kmax.}			l ₇	l ₁₀	l ₁₁	l ₁₂	l ₂₀	N	L
65	940	1880	3450	1880	16	112,5	113,5	166,0	135	150	344,5
75	1920	3840	3250	3840	19	131,5	133,0	166,5	135	150	374,5
90	3600	7200	3000	7200	20	164,0	165,5	206,5	175	190	454,0
100	4950	9900	2800	9900	25	153,5	155,0	206,5	175	190	458,5
110	7200	14400	2600	14400	26	201,5	203,5	212,0	180	195	518,5
125	10000	20000	2250	20000	30	198,5	200,5	212,0	180	195	528,5
140	12800	25600	1800	25600	34	244,5	247,0	252,5	220	235	627,5
									210 ³⁾	230 ³⁾	
160	19200	38400	1500	38400	38	226,5	229,0	252,5	220	235	627,5
									210 ³⁾	230 ³⁾	

Selection of ROTEX® coupling/disk brake											
Size	Brake disk ØA x b ₁										
	355x30	400x30	450x30	500x30	560x30	630x30	710x30	800x30	900x30	900x40	1000x40
65	x	x	x								
75		x	x	x							
90			x	x	x	x					
100				x	x	x					
110				x	x	x	x				
125						x	x	x			
140							x	x	x	x	x
160								x	x	x	x

¹⁾ Selection see page 20/21 ²⁾ The max. braking torque must not exceed the maximum torque of the coupling. ³⁾ Dimensions for a brake disk width b₁ of 40 mm.

Order form:	ROTEX® 90	AFN-SB special	Ø450x30	95 Sh-A	4Nv – Ø 90	4Nx – Ø 90
Coupling size		Type	ØDisk brake width of disk	Spider hardness	Component	Finish bore

Type SD (shiftable at standstill)



- Shiftable shaft coupling for all applications in general engineering
- Easy to engage and disengage driving or driven machines with standstill of machine
- Existing shifting hub to be combined with slip ring and shiftable linkage
- With pilot bored shifting hubs the requested shifting force must be set after final machining
- Other sizes on request according to M 370266
- Complete shifting device consisting of:
separated slip ring from red bronze, shift fork, shifting shaft, shifting lever, eye type bearing

Components

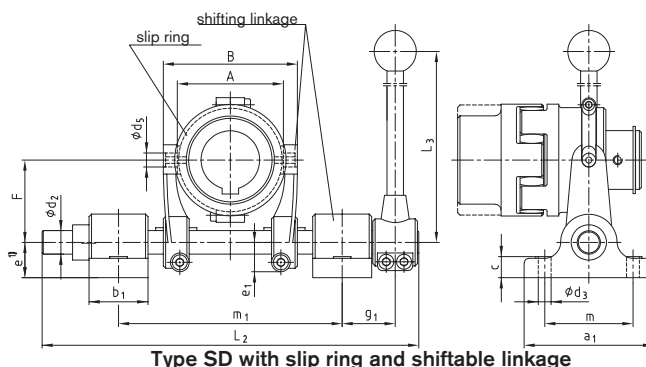
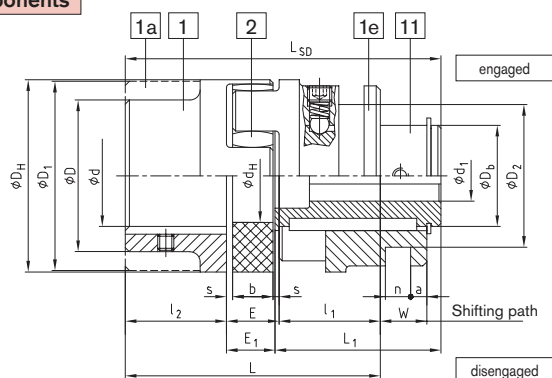

ROTEX® type SD (No. 015)

Size	Ød ØD ØD ₁	Finish bore d ₁		Dimensions [mm]															Shifting force set in [N]	Slip ring size	Shiftable linkage size
		min.	max.	D _H	D ₂ ±0,1	D _b	d _H	l ₁ :l ₂	E	s	b	E ₁	L	L ₁	W	a	n±0,1	L _{SD}			
24	8	18	55	41	30	27	30	18	2,0	14	16,5	78	51,5	16,0	6	6,0	98	110	—	—	
28	10	22	65	58	36	30	35	20	2,5	15	18,0	90	60,0	17,5	8	8,0	113	130	—	—	
38	12	28	80	70,5	45	38	45	24	3,0	18	22,0	114	73,0	21,0	8	12,5	140	150	1,1	1	
42	14	32	95	70,5	50	46	50	26	3,0	20	24,0	126	82,0	23,0	8	12,5	156	180	1,1	1	
48	15	40	105	89,5	60	51	56	28	3,5	21	25,5	140	90,5	24,5	6	17,5	172	200	2,2	2	
55	18	48	120	112,5	70	60	65	30	4,0	22	27,0	160	103,0	26,0	6	18,0	195	250	3,3	3	
65	20	55	135	112,5	80	68	75	35	4,5	26	32,0	185	120,0	30,5	7	18,0	227	280	3,3	3	
75	25	65	160	130,5	95	80	85	40	5,0	30	37,0	210	135,0	35,0	6	20,5	257	350	4,4	3	
90	28	75	200	164,5	110	100	100	45	5,5	34	41,0	245	152,0	39,5	8	25,5	293	350	5,5	4	
100	30	80	225	164,5	115	113	110	50	6,0	38	46,0	270	169,0	44,0	14	25,5	325	380	5,5	4	
110	35	85	255	164,5	125	127	120	55	6,5	42	51,5	295	184,0	48,5	18,5	25,5	355	450	5,5	4	
125	40	100	290	210,5	145	147	140	60	7,0	46	55,5	340	208,5	53,0	18,5	30,5	404	500	6,6	5	

Slip ring and shiftable linkage

Size	Shiftable linkage size	Dimensions [mm]																	Max. speed n for slip ring [rpm]
		a ₁	b ₁	c	d ₂	d ₃	d ₅	e ¹⁾	e ₁	F	g ₁	L ₂	L ₃	m	m ₁ min.	m ₁ max.	A	B	
38	1	110	50	18	20	11	12	30	25	70	55	320	400	75	180	190	90	114	3280
42	1								27	97,5	60	430	450		240	270	111	151	2550
48	2				25														
55	3	140					17	40	32,5	120	70	490	600	100	280	310	140	180	2120
65	3				30														
75	3		60	25		13,5											170	210	1710
90	4																		
100	4	160			35		21	50	37,5	147,5	70	565	750	120	321	365	200	244	1360
110	4																		
125	5				40		25		46	190	80	630	1085		365	410	250	300	855

¹⁾ In case of a through base plate the dimension „e“ of the shiftable linkage size 5 has to be increased by at least 10 mm.

Finish bore according to ISO fit H7, feather keyway according to DIN 6885 sheet 1 - JS9

Order form:

ROTEX® 38	SD	with 1,1 and 1	92 Sh-A	1	- Ø 38	11	- Ø 28
Coupling size	Type	with slip ring 1,1 and shiftable linkage 1	Spider hardness	Component	Finish bore	Component	Finish bore

Type FNN and FNN with fan

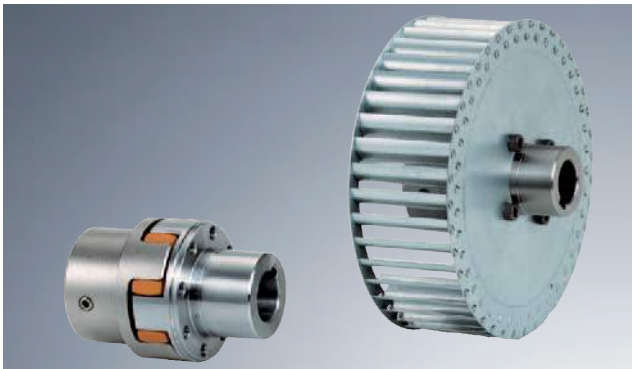

- Damping vibrations and reducing noise
- Ideal compensation for misalignment due to crowned teeth
- Coupling as plug-in design
- Easy checking of wear by sight control
- Coupling to be equipped with any fan
- Finish bore according to ISO fit H7, feather keyway according to DIN 6885 sheet 1 - JS9

Components

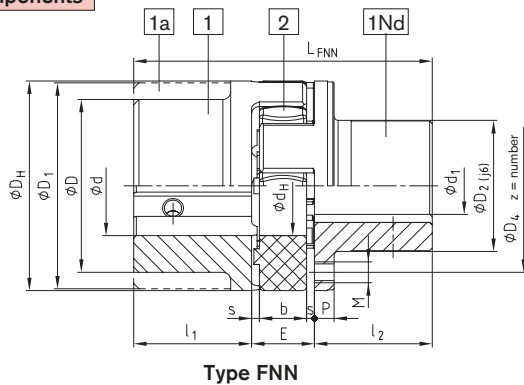

Type FNN

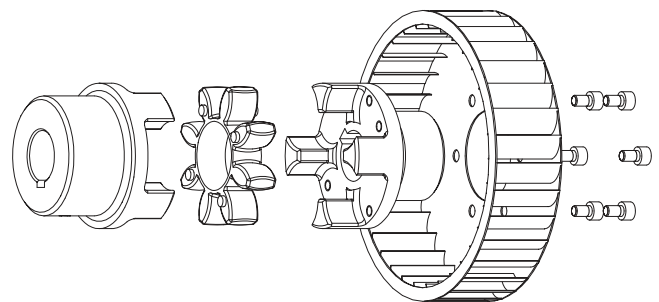

Type FNN with fan (typ 1)

ROTEX® type FNN (No. 021)

Size	Ød ØD ØD ₁	max. finish bore Ød ₁	Dimensions [mm]												
			D _H	D ₂	D ₄	d _H	E	s	b	l ₁ :l ₂	P	M	z	Pitch	L _{FNN}
28	see shaft coupling on pages 30 and 31; stock programme/basic programme see pages 28 and 29	24	65	40	54	30	20	2,5	15	35	6,5	M6	8	8x45°	90
38		34	80	50	66	38	24	3,0	18	45	7,5	M8	8		114
42		42	95	60	80	46	26	3,0	20	50	9,5	M8	12		126
48		48	105	68	90	51	28	3,5	21	56	10,5	M8	12	16x22,5°	140
55		55	120	78	102	60	30	4,0	22	65	12,5	M10	8	8x45°	160
65		65	135	92	116	68	35	4,5	26	75	13,5	M10	12	16x22,5°	185
75		75	160	106	136	80	40	5,0	30	85	15,5	M12	15	20x18°	210
90		100	200	140	172	100	45	5,5	34	100	18,5	M16	15		245

Other sizes on request

Type 1: Fan screwed on

The ROTEX® coupling can be supplied with the fan screwed on. Specific connection dimensions of customers such as pitch circle of threads, size of threads and number of centering of fans should be mentioned in your inquiry.

Type 2: Fans injection-moulded

Low prices due to production volumes depending on quantity.

Type 3: Fans pressed or glued on

Special surface forming (knurling according to DIN 82) allows the fan to be pressed or glued onto the hub collar.



Order form:

ROTEX® 38	FNN	92 Sh A	1	–	Ø 38	1Nd	–	Ø 30
Coupling size	Type	Spider hardness	Component		Finish bore	Component		Finish bore

Further types with clamping sets

Components

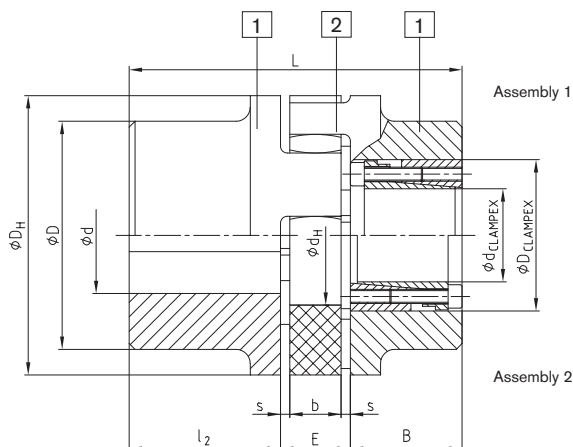

ROTEX® type No. 001 with clamping set CLAMPEX® KTR 200														
Size	ϕd ϕD ϕD_1	Hub material	CLAMPEX® KTR 200			B	Dimensions [mm]							
			Largest poss KTR clamping set dxD	Transmittable torques and force			l_2	E	s	b	D_H	D	d_H	L
				T [Nm]	F_{AX} [kN]									
42		Steel part 1	30x55	769	51	48	50	26	3,0	20	95	—	46	length L = $l_2 + E + B$ (clamping set)
48			35x60	1197	68	48	56	28	3,5	21	105	—	51	
55			45x75	2132	95	59	65	30	4,0	22	120	—	60	
65			45x75	2132	95	59	75	35	4,5	26	135	115	68	
75			50x80	3159	126	59	85	40	5,0	30	160	135	80	
90			65x95	4107	126	59	100	45	5,5	34	200	160	100	
100			65x95	4107	126	59	110	50	6,0	38	225	180	113	
110		GJS part 1	70x110	7023	201	70	120	55	6,5	42	255	200	127	length L = $l_2 + E + B$ (clamping set)
125			80x120	8026	201	70	140	60	7,0	46	290	230	147	
140			95x135	11373	239	70	155	65	7,5	50	320	255	165	
160			110x155	16068	292	80	175	75	9,0	57	370	290	190	
180			120x165	21910	365	80	195	85	10,5	64	420	325	220	

ROTEX® type No. 001 with clamping set CLAMPEX® KTR 200																	
KTR 200 Size	Length	Transmittable torque and axial force		Clamping screw DIN EN ISO 4762 - 12.9		KTR 200 Size	Length	Transmittable torque and axial force		Clamping screw DIN EN ISO 4762 - 12.9		KTR 200 Size	Length	Transmittable torque and axial force		Clamping screw DIN EN ISO 4762 - 12.9	
dxD	B	T [Nm]	F_{ax} [kN]	zxM	T_A [Nm]	dxD	B	T [Nm]	F_{ax} [kN]	zxM	T_A [Nm]	dxD	B	T [Nm]	F_{ax} [kN]	zxM	T_A [Nm]
20x47	48	513	51	6xM6	17	38x65	48	1299	68	8xM6	17	65x95	59	4107	126	8xM8	41
22x47	48	564	51	6xM6	17	40x65	48	1368	68	8xM6	17	70x110	70	7023	201	8xM10	83
24x50	48	616	51	6xM6	17	42x75	59	1990	95	6xM8	41	75x115	70	7524	201	8xM10	83
25x50	48	641	51	6xM6	17	45x75	59	2132	95	6xM8	41	80x120	70	8026	201	8xM10	83
28x50	48	718	51	6xM6	17	48x80	59	3033	126	8xM8	41	85x125	70	10659	251	10xM10	83
30x55	48	769	51	6xM6	17	50x80	59	3159	126	8xM8	41	90x130	70	11286	251	10xM10	83
32x60	48	1094	68	8xM6	17	55x85	59	3475	126	8xM8	41	95x135	66	11373	239	10xM10	83
35x60	48	1197	68	8xM6	17	60x90	59	3791	126	8xM8	41	for further details please see CLAMPEX® catalogue					

Design 4.2 with CLAMPEX® clamping set KTR 250

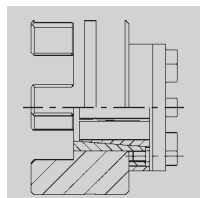

Frictionally engaged, backlash-free shaft-hub-connection for transmission of average torques.

Design 4.3 with CLAMPEX® clamping set KTR 400

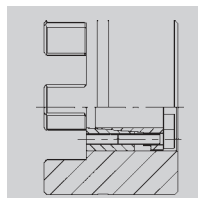

Frictionally engaged, backlash-free shaft-hub-connection for transmission of larger torques. Largest clamping set possible depends on the hub collar diameter. Clamping set screw fitting possible both internally and externally. For details of calculation please see CLAMPEX® catalogue.

Further types with torque limiter

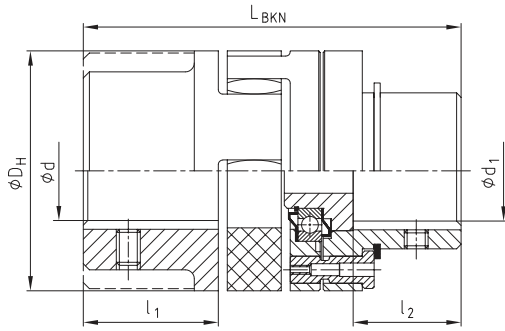

ROTEX® BKN - shear pin coupling, type BKN No. 009							
Size	Max. finish bore d	Max. finish bore d ₁	l ₁	l ₂	L _{BKN}	D _H	Min. fracture torque [Nm]
28	see shaft coupling on pages 30 and 31 basic programme see pages 28 and 29	28	35	25	101	65	100
38		38	45	35	125	80	190
42		42	50	40	139	95	250
48		48	56	46	153	105	300
55		55	65	55	177	120	400
65		65	75	65	202	135	500
75		75	85	70	230	160	600
90		100	100	85	266	200	700

Modification for customer from the stock programme.
Please mention the fracture torques with your order!
For further details please see dim. sheet no. 5020/000/009-7603

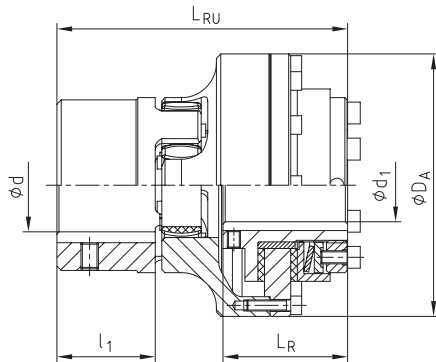

ROTEX® - RUFLEX® - coupling with torque limiter, type No. 070								
ROTEX® Size	RUFLEX® Size	Slipping torques [Nm]	d	d ₁ max.	D _A	l ₁	L _R	L _{RU}
14	00	0,5 – 5	see shaft coupling on pages 30 and 31 basic programme see pages 28 and 29	10	44	11	31	59
19	0	2 – 20		20 ¹⁾	63	25	33	78
24	01	5 – 70		22	80	30	45	98
28	1	20 – 200		25	98	35	52	113
38	2	25 – 400		35	120	45	57	133
48	3	50 – 800		45	162	56	68	166
75	4	90 – 1600		55	185	85	78	205

¹⁾ Finish bore exceeding ø 19, keyway according to 6885 sheet 3

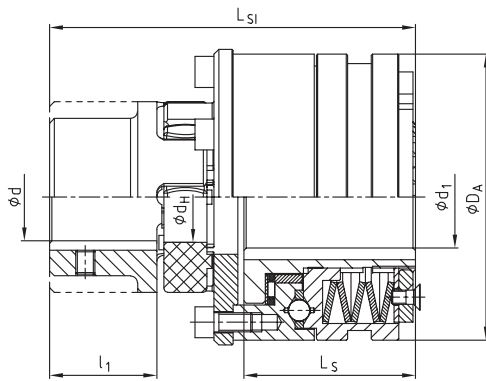

ROTEX® - KTR-SI - coupling with torque limiter, type No. 070									
ROTEX® Size	KTR-SI design	KTR-SI Size	Ratchet torque [Nm]	d	max. d ₁	D _A	l ₁	L _S	L _{SI}
28	DK	2	12-200	see shaft coupling on pages 30 and 31 basic programme see pages 28 and 29	35	100	35	56	124
	SR/SGR	0	5-40		20	55		34,5	102
38	DK	3	25-450		45	120	45	73	155
	SR/SGR	1	12-100		25	82		48	129,5
48	DK	4	50-1000		55	146	56	93,5	194
	SR/SGR	2	25-200		35	100		56	155
55	DK	5	85-2000		65	176	65	107	222,5
	SR/SGR	3	50-450		45	120		73	186
75	DK	—	—	—	—	85	—	—	
	SR/SGR	4	100-2000	55	146		93,5	241,5	
90	DK	—	—	—	—	100	—	—	
	SR/SGR	5	170-3400	65	176		107	275,5	

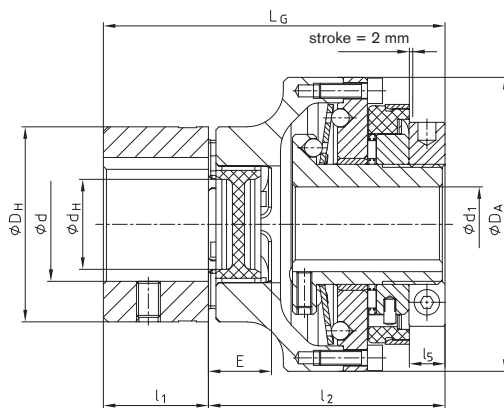

SYNTAX® - backlash-free, torsionally rigid overload coupling with ROTEX® GS																
ROTEX® Size	SYNTAX® Size	SYNTAX® torque range disk spring [Nm]				Max. bore		D _A	D _H	d _H	E	L	L _G	l ₁	l ₂	l ₅
		DK ₁	DK ₂	SK ₁	SK ₂	d	d ₁									
24	20	6-20	15-30	10-20	20-65	35	20	80	55	27	18	45	100	30	70	10
28	25	20-60	45-90	25-65	40-100	40	25	98	65	30	20	50	113	35	78	11
38	35	25-80	75-150	30-100	70-180	48	35	120	80	38	24	60	136	45	91	13
48	50	60-180	175-300	80-280	160-400	55	50	162	105	51	28	70	167	56	111	14

Weights and mass moment of inertia

Components

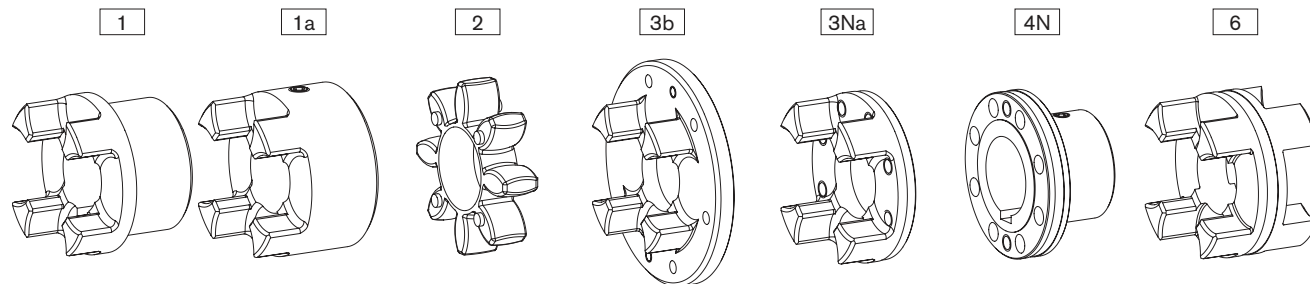

ROTEX® components													
Size	Standard hub				Large hub			Spider	Driving flange			Coupling flange	DKM spacer
	Part 1				Part 1a			Part 2	Part 3b	Part 3Na		Part 4N	Part 6
	Alu [kg] [kgm²]	GJL [kg] [kgm²]	GJS [kg] [kgm²]	St [kg] [kgm²]	Alu [kg] [kgm²]	GJL [kg] [kgm²]	St [kg] [kgm²]	Polyurethan (Vulkollan) [kg] [kgm²]	GJS [kg] [kgm²]	St [kg] [kgm²]	GJS [kg] [kgm²]	St [kg] [kgm²]	Alu [kg] [kgm²]
14	—	—	—	—	0,020	—	—	0,0044	—	—	—	—	—
	—	—	—	—	0,000003	—	—	0,0000005	—	—	—	—	—
19	0,064	—	—	—	0,074	—	0,25	0,0056	—	—	—	—	—
	0,00001	—	—	—	0,00002	—	0,00006	0,000001	—	—	—	—	—
24	0,123	—	—	—	0,174	—	0,55	0,014	0,028	0,145	—	0,30	0,14
	0,00004	—	—	—	0,00008	—	0,00023	0,000006	0,00023	0,00007	—	0,00009	0,00006
28	0,200	—	—	—	0,264	—	0,89	0,024	0,54	0,232	—	0,49	0,22
	0,00010	—	—	—	0,00019	—	0,00053	0,000010	0,0007	0,00017	—	0,0002	0,00013
38	0,44	1,16	—	1,6	0,470	1,32	1,74	0,042	0,73	—	0,313	0,87	0,35
	0,00033	0,00086	—	0,00151	0,00046	0,00135	0,00155	0,00003	0,001	—	0,00038	0,0005	0,00035
42	0,69	1,75	—	2,44	0,772	2,05	2,74	0,065	1,26	—	0,608	1,4	0,47
	0,00067	0,00178	—	0,00281	0,00111	0,00291	0,00343	0,00007	0,0032	—	0,00089	0,0011	0,00068
48	0,80	2,44	—	3,34	1,01	2,78	3,72	0,086	1,45	—	0,755	1,92	0,62
	0,011	0,00308	—	0,00473	0,00174	0,00484	0,00570	0,00013	0,0043	—	0,001358	0,0018	0,0011
55	—	3,68	—	5,05	—	4,08	5,57	0,11	2,58	—	1,243	2,93	0,90
	—	0,00615	—	0,00948	—	0,00926	0,01193	0,00023	0,0105	—	0,002920	0,0037	0,0021
65	—	5,67	—	6,79	—	6,04	8,22	0,17	3,10	—	1,635	4,36	1,31
	—	0,01240	—	0,01516	—	0,01789	0,02079	0,00042	0,0149	—	0,004891	0,0069	0,0039
75	—	8,72	—	10,5	—	9,53	14,3	0,32	4,46	—	2,511	6,80	1,97
	—	0,02644	—	0,03269	—	0,03946	0,05069	0,00116	0,0281	—	0,01050	0,0151	0,0082
90	—	14,8	—	18,7	—	18,2	24,0	0,57	6,94	—	4,151	12,84	3,45
	—	0,06730	—	0,08742	—	0,15086	0,13151	0,00323	0,0651	—	0,02723	0,0448	0,0224
100	—	—	19,7	—	—	—	—	0,81	10,2	—	6,350	16,16	—
	—	—	0,11694	—	—	—	—	0,00588	0,1165	—	0,05273	0,0798	—
110	—	—	27,4	—	—	—	—	1,19	—	—	8,578	21,35	—
	—	—	0,20465	—	—	—	—	0,01097	—	—	0,09121	0,2824	—
125	—	—	42,3	—	—	—	—	1,63	—	—	12,598	34,33	—
	—	—	0,40727	—	—	—	—	0,01972	—	—	0,17469	0,3229	—
140	—	—	58,1	—	—	—	—	2,11	—	—	17,271	48,69	—
	—	—	0,67739	—	—	—	—	0,03129	—	—	0,29247	0,4917	—
160	—	—	84,2	—	—	—	—	3,21	—	—	26,305	71,08	—
	—	—	1,31729	—	—	—	—	0,06323	—	—	0,59436	0,9693	—
180	—	—	118,5	—	—	—	—	5,25	—	—	33,076	109,43	—
	—	—	2,30835	—	—	—	—	0,13789	—	—	0,97394	1,9650	—

Weight and mass moment of inertia each refer to the medial finish bore without keyway.

Weights and mass moment of inertia

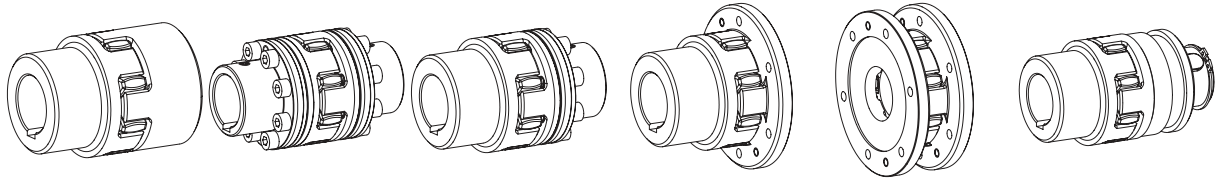

ROTEX® complete couplings												
Size	Standard		AFN		BFN		CF		DF		SD	
	Weight [kg]	Mass moment of inertia J [kgm²]	Weight [kg]	Mass moment of inertia J [kgm²]	Weight [kg]	Mass moment of inertia J [kgm²]	Weight [kg]	Mass moment of inertia J [kgm²]	Weight [kg]	Mass moment of inertia J [kgm²]	Weight [kg]	Mass moment of inertia J [kgm²]
19	0,51	0,000121	—	—	—	—	0,44	0,00016	0,38	0,00020	0,42	0,00008
24	1,1	0,000466	0,98	0,00036	1,1	0,00041	0,84	0,00047	0,57	0,00047	1,1	0,00046
28	1,8	0,00107	1,6	0,00083	1,7	0,00095	1,5	0,00124	1,1	0,00141	1,9	0,00106
38	2,5	0,00171	2,8	0,00209	2,6	0,00193	1,9	0,00217	1,5	0,00259	3,0	0,00435
42	3,9	0,00476	4,5	0,00472	4,1	0,00419	3,1	0,00513	2,6	0,00662	4,4	0,00804
48	5,3	0,00805	5,9	0,00736	5,5	0,00684	3,9	0,00755	3,0	0,00881	6,2	0,00223
55	7,9	0,01564	8,9	0,01480	8,3	0,01369	6,4	0,01692	5,3	0,02131	9,8	0,0166
65	11,9	0,03071	12,9	0,0266	12,3	0,0259	8,9	0,02780	6,4	0,003037	14,9	0,0326
75	18,6	0,06706	20,6	0,0601	19,3	0,0572	13,5	0,0557	9,2	0,05741	23,2	0,0706
90	33,6	0,22139	37,8	0,1718	34,2	0,1551	22,3	0,1356	14,5	0,1333	40,5	0,1891
100	40,2	0,23976	49,6	0,3068	45,2	0,2737	30,9	0,2401	21,2	0,2394	46,7	0,2467
110	56,0	0,42027	67,5	0,5385	61,7	0,4793	42,9	0,4324	29,8	0,4446	61,5	0,4186
125	86,2	0,83426	102,6	1,0485	94,4	0,9413	64,4	0,8187	42,2	0,8031	96,8	0,8497
140	118,3	1,38607	141,2	1,743	129,7	1,564	90,4	1,4221	62,5	1,4580	127,8	1,368
160	171,6	2,69781	210,3	3,517	190,9	3,107	127,6	2,589	83,6	2,4805	190,3	2,723
180	242,25	4,75449	306,6	6,582	274,4	5,668	175,1	4,448	107,9	4,141	262,2	4,810

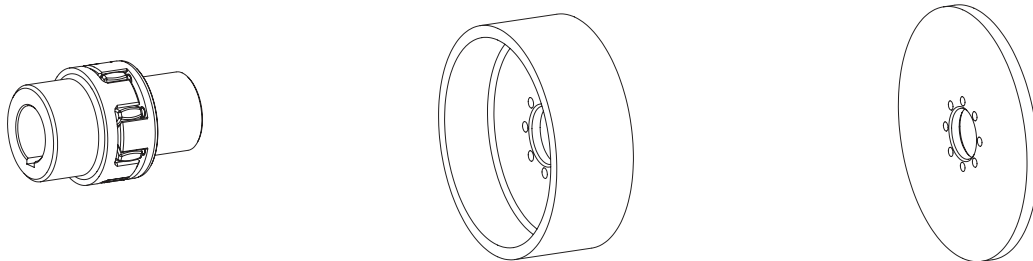

BTAN/SBAN without drum/disk		
Size	Weight [kg]	Mass moment of inertia J [kgm²]
28	0,90	0,0004
38	2,10	0,0014
42	3,24	0,0031
48	4,41	0,0053
55	6,60	0,0105
65	10,1	0,0209
75	15,4	0,0442
90	27,6	0,1224
100	36,9	0,2074
110	50,9	0,3665
125	79,1	0,7349
140	109,0	1,2292
160	161,9	2,4569
180	232,9	4,4967

Drum for BTAN ¹⁾		
Brake disk Ø _{D_B} x B	Weight [kg]	Mass moment of inertia J [kgm²]
160 x 60	2,12	0,01
200 x 75	3,45	0,03
250 x 95	6,87	0,08
315 x 118	14,95	0,28
400 x 150	31,20	0,89
500 x 190	60,00	2,70
630 x 236	112,00	8,01
710 x 265	161,00	14,9
800 x 300	202,00	27,2

Disk for SBAN ¹⁾		
Disk brake Ø _A x G _S	Weight [kg]	Mass moment of inertia J [kgm²]
200 x 12,5	2,928	0,015367
250 x 12,5	4,662	0,037584
315 x 16	8,618	0,111829
400 x 16	15,230	0,315206
500 x 16	23,964	0,769963
630 x 20	47,716	2,426359
710 x 20	60,934	3,915100
800 x 25	94,913	7,878998
900 x 25	118,954	12,609089
1000 x 25	148,240	19,234941

Weights and mass moments of inertia refer to standard hub with medial bore without keyway.

¹⁾ Selection of ROTEX® brake drum - disk brake please see page 41.